

# SECURE IOT BASED INDUSTRIAL CONTROL SYSTEMS

**V.Gomathi, M.E.,**

PG Scholar, National Engineering College, Kovilpatti.

[goms2dec92@gmail.com](mailto:goms2dec92@gmail.com)

**Mr. T.Devakumar, M.E.,**

Assistant Professor, National Engineering College, Kovilpatti.

[tdkece@nec.edu.in](mailto:tdkece@nec.edu.in)

## ABSTRACT

To solve perplexed of connecting wireless sensor node quandaries, an incipient method is proposed to design a reconfigurable astute sensor interface for industrial WSN in IoT environment, in which involute programmable logic contrivance (CPLD) is adopted as the core controller. WSNs consist of distributed sensors used to remotely accumulate physical or environmental information. A sensor interface contrivance is essential for sensor data amassment of industrial wireless sensor networks (WSN) in IoT environments. Meanwhile, in the Internet of Things (IoT) environment, each sensor connected to the contrivance is required to indite perplexed and some data amassment program code. Performance of the proposed system is verified and good effects are achieved in practical application of IoT to Industrial environment monitoring. For research purport, implemented a temperature and PIR sensor for monitoring application of Industrial automations.

**KEYWORD:** *Internet of Things (IoT), Complex Programmable Logic Device (CPLD), Sensor Data Acquisitions, Wireless Sensor Network (WSN), Industrial Control System (ICS).*

## 1. INTRODUCTION

Industrial control system (ICS) is a consequential term, which has been dedicating for monitoring and controlling of industrial infrastructures such as Oil, Gas, Manufacturing, Electricity and Conveyance, and others are often employed in several industrial sectors of current era.

Wireless sensor networks (WSN) has been employed to amass data about physical phenomena in sundry applications such as habitat monitoring, and ocean monitoring, and surveillance. Some of the information accumulated by sensors is: temperature levels, sultriness levels, vehicular kineticism, lightning condition, pressure levels, soil makeup, noise levels, the presence or absence of certain kinds of objects, mechanical stress levels on annexed objects, and speed/direction/size of an object. As an emerging technology established rapid advances in modern wireless telecommunication, Internet of Things (IoT) has magnetized an abundance of attention and is expected to bring benefits to numerous application areas including industrial WSN systems, and healthcare systems manufacturing.

Simply put, that the Internet of Things (IoT) is the concept of fundamentally connecting any contrivance with an on and off switch to the Internet (and/or to each other). This includes everything from cell phones, coffee makers, washing machines, headphones, lamps, wearable

contrivances and virtually anything else you can celebrate of. This withal applies to components of machines, etc. The IoT is a giant network of connected "things" (which withal includes people). The relationship will be between people-people, people-things, and things-things.

## 2. LITERATURE SURVEY

To eschew accidents in industries due to system error, by we have to control the system parameter instantly i.e. to monitoring and controlling the industrial machine parameter from anywhere, anytime by utilizing internet. In this system we amass the data from the sensor and made it available to the utilizer from remote location. It is not an automatic controlling method. An operator must require for controlling the unit. If operator not concentrate the shown undesirable value, the system not get control signal from web that time chance to fault occurs in industry [1].

The above visually perceived WSN are facilely tracked by assailers. But in this system we utilize the secure BSL 64 bit op-code injuctive authorizations for our monitoring system access to achieve high security. It not have a randomized password, the given password was constant, if a person have erudition about the BSL op-code we utilize reverse engineering to facilely find that. So we require supplemental software development for randomized password like OTP [2].

Utilizing the standard of IEEE1451.2 for sensor interfacing to design CLPD. By utilizing that Involute Logical Programming Contrivance to reconfigure the sensor interface, so we facilely configure the sensor interface to eliminate the restriction on parameter values like sampling rate, signal type of interfacing contrivance. By which we sense any signal from different sensor utilizing single interfacing contrivance. It requires analog to digital conversion block as external unit so adscititious space desideratum for that. The IEEE 1451.2 standard designations are more sumptuous [3].

It diagnostic the quandaries and allocates the congruous resource to patients with remote access manner. This is done by set of grouped datasets, predicated on the answer from patients decision is taken. The system sometimes have illimitable loop it may be caused by the paucity of datasets in the erudition base and the difference among different medicos [4].

By utilizing some kind of iot controlled IT datasets to achieve the automated manufacturing system. It can be done by lot of machine parameter datasets and designing protocols. These things are stuffed in IT systems like CNC, CAD, and CAPP., to achieve IOT controlled manufacturing. It requires very sumptuous software's with highly erudite operator. It make a situation of only run by a particular software, if any fault in software total manufacturing is stop [5].

To amend the celerity of transmission by compressing the output of sensor signals to achieve profoundly expeditious IOT. So the data acquisition process has adscititious speed compare

to other systems. This compressing and reconstruction has chance of data loss withal some posits are taken when reconstruction process some time it make an erroneous information [6].

By utilizing this system the controlling person monitor the whole system if he is in the plant or in alfresco. It additionally enables high bandwidth video streaming to visually perceive the physical structure with current situation of plant either in very long distance. The system plenary predicated on wifi networks with less level security so the chance to any persons facilely interact our system. Wireless sensor network need some specialized hardware for this is very sumptuous [7].

Allow the students to make experiments in our home with a real lab by using plc with SCADA. The distance lab experiments make the condition of without supervising so the chance to get accidence easily with unknowledgeable student. Also it only have a security of username & password, if student share his personal id anyone easily enter our lab [8].

Easily find out the repair in machineries also it monitoring the output power of system to maintain the efficiency of our system by dynamic power management algorithm. It have some interval of time for battery capacity recovery that time we just monitoring the system, that time no communication links are present. Dynamic response is slow [9].

Each and every sub systems in our plant are interred connected to control it all by a single unit with security. This controlling done by using Distributed Control System and PLC. SCADA and ICS are best way for controlling a plant. But this controlling operations must be done by a operator & he must within a particular operating point. If the person is not nearer to the controlling unit he not able to monitor and controlling the system. So we need a remote access method for our system to produce a more stable ICS [10].

### **3. EXISTING SYSTEM DISADVANTAGES**

With rapid development of IoT, major manufacturers are dedicated to the research of multi sensor acquisition interface equipment. There is a plethora of data acquisition multiple interface equipment's with mature technologies on the market. But these interface contrivances are very specialized in working style, so they are not individually adaptable to the transmuring IoT environment. Meanwhile, these ecumenical data acquisition interfaces are often restricted in physical properties of sensors (the connect number, sampling rate, and signal types). In Conventional of WSN it performs a task by way of interrupt, which makes these multi sensor acquisition interfaces not authentically parallel in amassing multi sensor data.

#### 4. PROPOSED SYSTEM

Sensor data acquisition interface equipment is one of the key components in IoT applications. Data amassment is the essential application of WSN and more importantly it is the substratum of other advanced applications in IoT environment. IoT is a major drive to fortify accommodation composition with sundry applications. The proposed architecture of WSN Base IoT is consists of three layers.

1. Sensor Node;
2. Network layer
3. Monitoring & Control Station

Our proposed model block diagram is shown below.

#### BLOCK DIAGRAM:

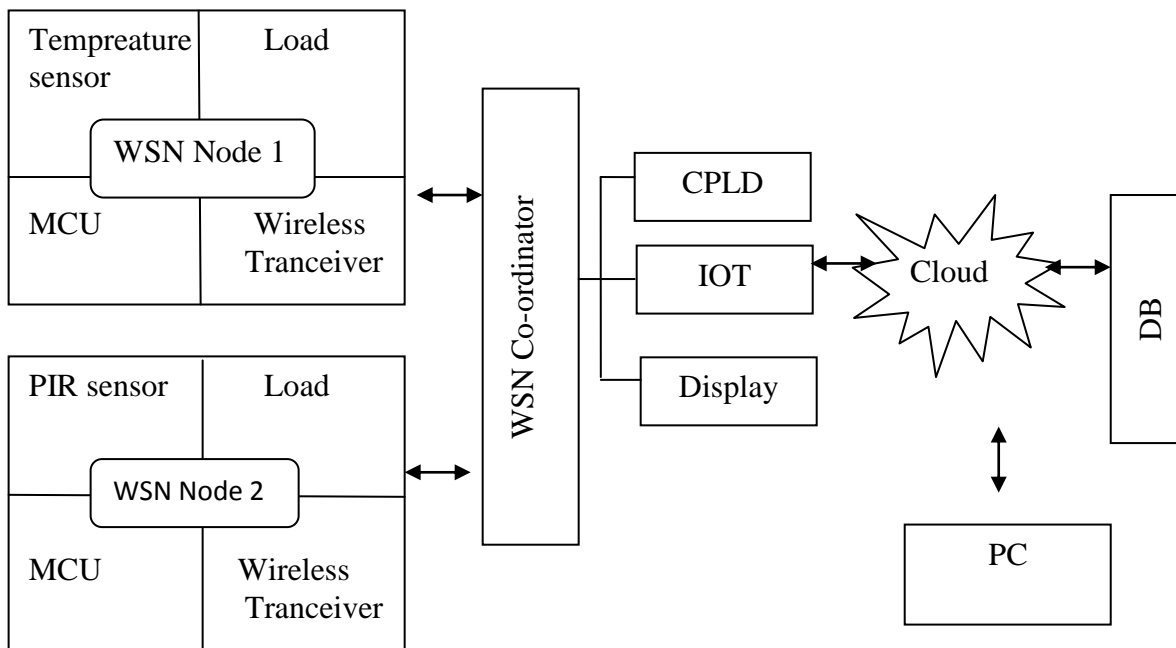

**Fig: 1. Block diagram of proposed model**

The design of reconfigurable perspicacious sensor interface contrivance that integrates data accumulation, data processing, and wireless transmission together. The interface contrivance can automatically discover sensors connected to it, and to amass multiple sets of sensor data astutely, and parallel with high-celerity.

CPLD is core controller of the interface contrivance. It is utilized to control data acquisition, processing, and transmission astutely, and make some preprocessing work for the amassed data. In terms of data transmission, our design can achieve wireless communication through Xbee module. Consequently, we can cull different transmission mode of the contrivance in different industrial application environments. The accumulated data can be transmitted to the host computer side by way of IOT, so that the utilizer can analyze and process the data.

## 5. COMPONENTS DESCRIPTIONS

### ➤ HARDWARE DESCRIPTION:

- MCU PIC16f877a ( WSN Node Block )
- CPLD ARM7 ( WSN Coordinator Block)
- Xbee Module ( RFX240)
- IOT Module
- Temperature Sensor
- PIR Sensor
- Fan, Light ( Load )
- Relay Module
- Display
- PC

### ➤ SOFTWARE DESCRIPTION:

- MPLAB – IDE
- Keil4 – IDE
- WINPIC
- Flashmagic
- PROTUES

## 6. RESULT AND DISCUSSION

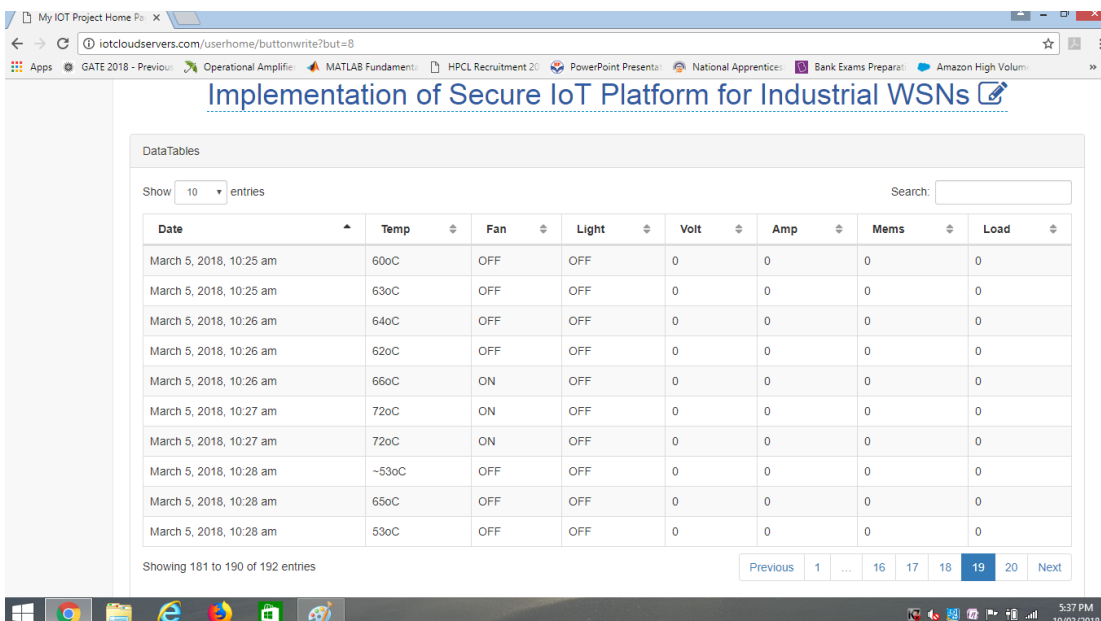

Implementation of Secure IoT Platform for Industrial WSNs

DataTables

Show  entries Search:

Date	Temp	Fan	Light	Volt	Amp	Mems	Load
March 5, 2018, 10:25 am	60oC	OFF	OFF	0	0	0	0
March 5, 2018, 10:25 am	63oC	OFF	OFF	0	0	0	0
March 5, 2018, 10:26 am	64oC	OFF	OFF	0	0	0	0
March 5, 2018, 10:26 am	62oC	OFF	OFF	0	0	0	0
March 5, 2018, 10:26 am	66oC	ON	OFF	0	0	0	0
March 5, 2018, 10:27 am	72oC	ON	OFF	0	0	0	0
March 5, 2018, 10:27 am	72oC	ON	OFF	0	0	0	0
March 5, 2018, 10:28 am	~53oC	OFF	OFF	0	0	0	0
March 5, 2018, 10:28 am	65oC	OFF	OFF	0	0	0	0
March 5, 2018, 10:28 am	53oC	OFF	OFF	0	0	0	0

Showing 181 to 190 of 192 entries

Previous 1 ... 16 17 18 19 20 Next

5:37 PM 10/03/2018

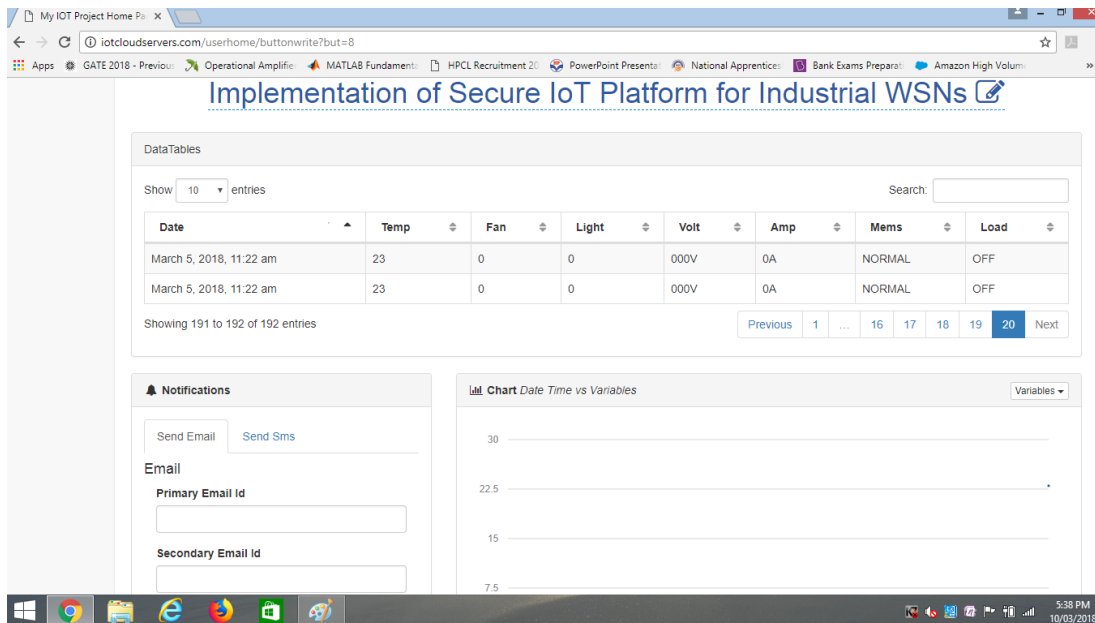

Here, when temperature reaches to or above  $66^{\circ}\text{C}$ , the fan will be in ON and the light will be OFF condition. Finally, IoT result is  $23^{\circ}\text{C}$  temperature, Fan 0, Light 0, Volt 000v, Current 0A, Mems Normal and Load is in OFF.

## 7. CONCLUSION

This paper describes a reconfigurable keenly intellectual sensor interface for industrial WSN in IoT environment. The system can accumulate sensor data perspicaciously and cumulating with CPLD and the application of wireless communication. It is very opportune for authentic-time and efficacious requisites of the high-speed data acquisition system in IoT environment. The application of CPLD greatly simplifies the design of peripheral circuit, and makes the whole system more flexible and extensible. Main design method of the reconfigurable keenly intellectual sensor interface contrivance is described in this paper. Determinately, by taking authentic time monitoring of Industrial environment in IoT environment as an authentic time, we verified that the system achieved good effects in practical application.

## 8. REFERENCES

- [1] Sanket Raut, Dipak Jagadale, Amar Khatmode and Hajrat Patil, "IOT Based Industrial SCADA System ", INTERNATIONAL RESEARCH JOURNAL OF ENGINEERING AND TECHNOLOGY, Volume: 04 Issue: 04 | Apr -2017.
- [2] Mauricio Tellez, Samy El-Tawab, Hossain M Heydari and James Madison University, "**Improving the Security of Wireless Sensor Networks in a IoT Environmental Monitoring System**", IEEE SYSTEMS AND INFORMATION ENGINEERING DESIGN CONFERENCE, 2016.

- [3] Qingping Chi, Hairong Yan, Chuan Zhang and Li Da Xu Senior Member IEEE, “**A Reconfigurable Smart Sensor Interface for Industrial WSN in IoT Environment** ”, IEEE TRANSACTIONS ON INDUSTRIAL INFORMATICS, VOL. 10, NO. 2, MAY 2014
- [4] Yuan Jie Fan, Yue Hong Yin Member IEEE, Li Da Xu and Yan Zeng, “**IoT - Based Smart Rehabilitation System**”, IEEE TRANSACTIONS ON INDUSTRIAL INFORMATICS, VOL. 10, NO. 2, MAY 2014
- [5] Zhuming Bi - Senior Member IEEE, Li Da Xu - Senior Member IEEE and Chengen Wang - Senior Member IEEE, “**Internet of Things for Enterprise Systems of Modern Manufacturing** ”, IEEE TRANSACTIONS ON INDUSTRIAL INFORMATICS, VOL. 10, NO. 2, MAY 2014
- [6] Shancang Li, Li Da Xu and Xinheng Wang, “**Compressed Sensing Signal and Data Acquisition in Wireless Sensor Networks and Internet of Things** ”, IEEE TRANSACTIONS ON EDUCATION, VOL. 43, 2013
- [7] Li Li, Hu Xiaoguang, Chen Ke and He Ketai, “**The Applications Of WiFi - based Wireless Sensor Network In Internet Of Things And Smart Grid** ”, 6TH IEEE CONFERENCE ON INDUSTRIAL ELECTRONICS AND APPLICATIONS, 2011
- [8] Zafer Aydogmus and Omur Aydogmus, “**A Web-Based Remote Access Laboratory Using SCADA** ”, IEEE TRANSACTIONS ON EDUCATION, VOL. 52, NO. 1, FEBRUARY 2009
- [9] Fabiano Salvadori, Maurício de Campos, Paulo Sérgio Sausen, Robinson Figueiredo and Camila Gehrke, “**Monitoring in Industrial Systems Using Wireless Sensor Network With Dynamic Power Management** ”, IEEE TRANSACTIONS ON INSTRUMENTATION AND MEASUREMENT, VOL. 58, NO. 9, SEPTEMBER 2009
- [10] Keith Stouffer, Joe Falco and Karen Kent, “**Guide to Supervisory Control and Data Acquisition (SCADA) and Industrial Control Systems Security** ”, NATIONAL INSTITUTE OF STANDARDS AND TECHNOLOGY SPECIAL PUBLICATION, 2007.