

# Dynamic Quick Response Code Generator for Resume (Resumoder)

Ramnath B

<sup>#</sup>Computer Science Engineering, Kongunadu College of Engineering and Technology  
Thottiyam, Tiruchirapalli, Tamilnadu

<sup>1</sup>sharewithramnath@gmail.com

**Abstract**— The resume is the most important part of our professional life. Maintaining a good professional resume is the part of our carrier. A resume is a marketing tool in which the content should be adapted to suit each individual job application or applications aimed at a particular industry. The word resume comes from the French word resume meaning “summary”. Leonardo da Vinci is credited with the first resume though his “resume” takes the form of a letter written about 1481 – 1482 to a potential employer, Ludovico Sforza. For the roughly 450 years, the resume continued to be a mere description of a person and included their abilities and past employment. In the early 1900s, resumes listed things like weight, height, marital status, and religion. It wasn’t until 1950 that the resume evolved into something more than words written on scraps of paper. By then, resumes were considered very much mandatory, and started to include things like personal interests and hobbies. It wasn’t until the 1970s, the beginning of the digital age, that resumes took on a more professional look in terms of presentation and content. Now in future resume will get more technical evolution through this product. We can see lot of QR codes or mobile barcodes around us on websites, books, gadgets, T-shirts etc. which are making our work easier with just 1 click decode with high speed. With respect to old barcodes, QR-codes are very fast and they can store lot of data, making it more superior. QR-Codes originated within the technology hungry country of Japan and have only recently began to become popular within the Middle East and Europe. A barcode is an optical machine-readable exemplification of data relating to the object to which it is committed. Primitively barcodes represented data by varying the widths and spacing of parallel lines and may be referred to as linear or one-dimensional. Later they evolved into rectangles, dots, hexagons and other geometric patterns in two dimensions. Albeit 2D systems use a variety of symbols, they are in general referred to as barcodes as well. QR code stands for Quick Response Code, which is the trademark for the type of matrix barcode which was invented by the Japanese corporation Denso Wave. QR code has a number of features such as large capacity data encoding, dirt and damage resistant, high speed reading, small print out size, 360 degrees reading and structural flexibility of application. By integration of these two applications we can generate a dynamic quick response code for the resume. Whenever that QR-Code is scanned by the HR, the details about the person will be displayed in their mobile. In addition to that, by using the statistical analysis of a person’s resume, the system can be able to predict the character of that job seeker. By using the big data analytics, the character of the person will be analysed by the system and produce 99.9% accuracy in its result. This will helpful for the HR while choosing their employee simply by scanning the QR-Code. The main advantage of this QR-Code is the HR need not necessary to have any external device to scan the QR-Code, that he/she can simply scan it by

using their mobile phone camera irrespective of their platforms and device manufacturer.

**Keywords**— resume, barcode, qr code, Albeit 2D systems, dynamic QR code.

## I. INTRODUCTION

The Resumoder is an application for smart resume management system. This system is to provide service facility to Employee and also to the HR using QR code. The services that are provided is generation of QR code through the Server, job seeker information management and HR information management, character analysis information management and report. The main objective builds the system this is to provide smart character analyzing service to the HR about the job seeker using QR code.

## II. PROPOSED SYSTEM

The features of the proposed system are listed out below.,

- Decreases the workload of printing of resume.
- Analyze the character of Job seeker with 99% accuracy.
- In addition to scanning of jobseeker’s Resumoder code to view their details.
- This helps to view the last updated time of their resume to the HR.

## III. EXISTING SYSTEM

- Increased paper work.
- Printing of updated resume regularly.
- Workload of job seekers.

## IV. ARCHITECTURE DESIGN

The Architectural Diagrammatic explanation is given below.,

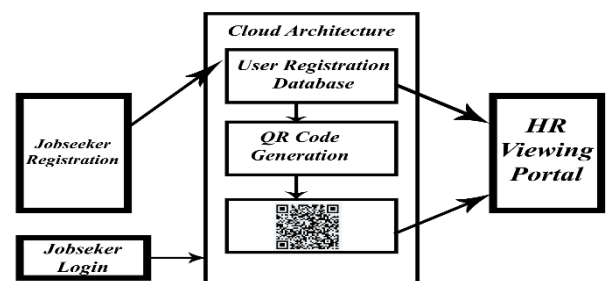

Fig. 1 Architecture Design

### V. ER DIAGRAM

The ER Diagram for the Resumoder is explained below in this part.,

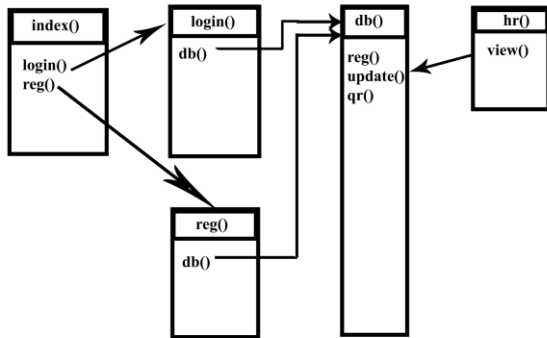

Fig. 2 ER Diagram

### VI. USE CASE DIAGRAM

The Use case diagram for Resumoder is explained below in this part.,

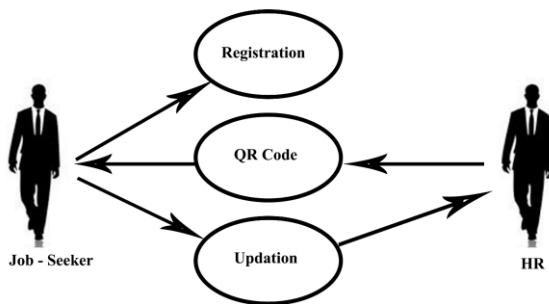

Fig. 3 Use Case Diagram

### VII. MODULES USED

- Job seeker Module
- Administrator Module
- HR Module
- QR code Generation Module
- AI Module

Those modules are explained clearly below.

#### A. Job Seeker Module

The job seeker need to register with the application first. The registered information is stored securely in the database system.

1) *User Registration form:* The job seeker registration form is simple and elegant for them to register. The screenshot of user registration form is given below.,

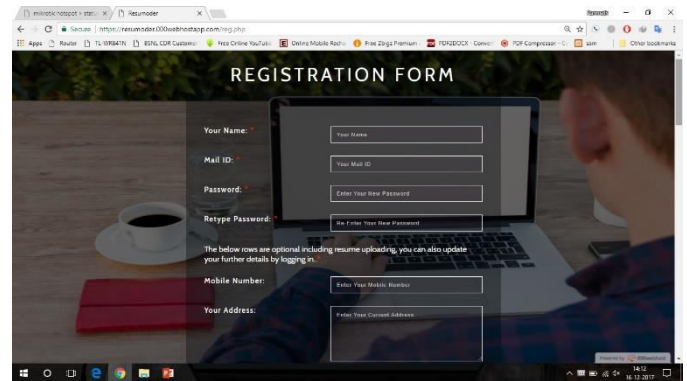

Fig. 4 User Registration Form Screenshot

2) *User Login:* The user after their registration can login with their system using their registered mail id and password. The screenshot of login form is given below.,

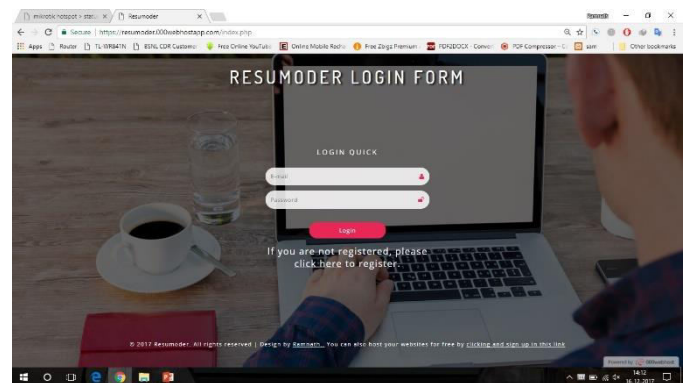

Fig. 5 User Login Form Screenshot

3) *User Updating module:* The QR code that is generated during the user registration can be able to download in the user updating module. The screen shot of user updating module is given below.,

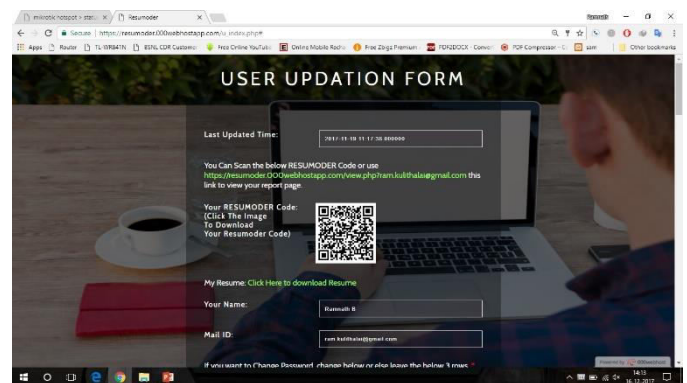

Fig. 6 User Updating Form Screenshot

### B. Administrator module

The maintenance of the server and the database is done by the administrator. And the administrator module is used to maintain the operational balance in the system. The screenshot of administrator module is given below. The system is developed using PHP. Hence the default administrator module is phpMyAdmin. The screenshot is given below.,

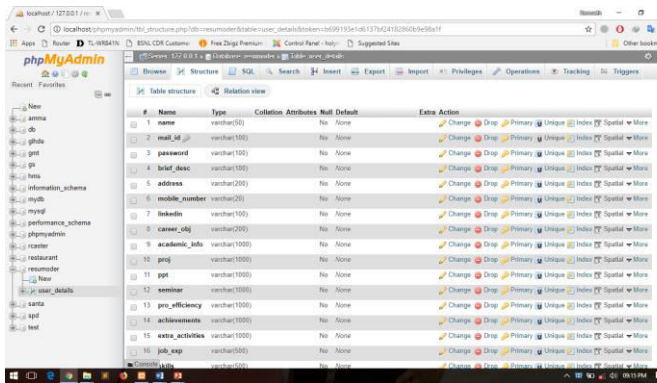

Fig. 7 Administrator Module Screenshot

### C. HR Module

In HR module the HR can be able to view the job seeker information and their personality using his mobile camera. This system is to provide service facility to Employee and also to the HR using QR code. Whenever that QR-Code is scanned by the HR, the details about the person will be displayed in their mobile. In addition to that, by using the statistical analysis of a person's resume, the system can be able to predict the character of that job seeker.

The screenshot of the HR module is given below.,

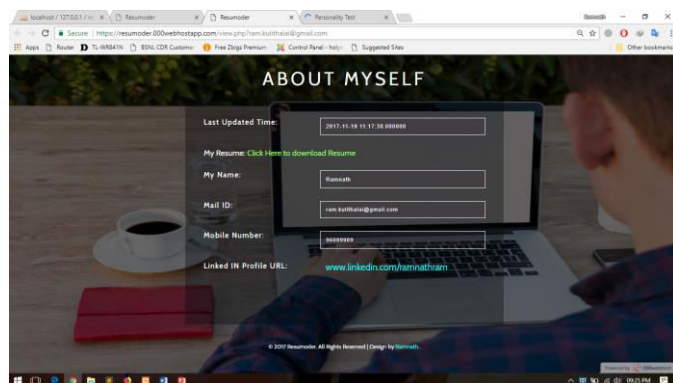

Fig. 8 HR Module Screenshot

### D. QR Code Generation Module

Quick Response (QR) codes seem to appear everywhere these days. We can see them on posters, magazine ads, websites, product packaging and so on. Using the QR codes is

one of the most intriguing ways of digitally connecting consumers to the internet via mobile phones since the mobile phones have become a basic necessity thing of everyone. In this paper, we present a methodology for creating QR codes by which the users enter text into a web browser and get the QR code generated. Drupal module was used in conjunction with the popular libqrencode C library to develop user interface on the web browser and encode data in a QR Code symbol. The experiment was conducted using single and multiple lines of text in both English and Thai languages. The result shows that all QR encoding outputs were successfully and correctly generated.

The algorithm of QR code generation is given below.,

#### QR code encoder:

First include the library from your local path

Include('qrlib.php');

Then o/p image directed as PNG stream

Qrcode::png('code');

### E. AI Module

The AI module takes responsibility in analysing the job seeker's personality. According the psychology studies, a person's character is based on the way he/she sees a system. This should vary from person to person. Hence by observing their visual observations the AI will statistically predicts a person's personality. This process can be done by asking questions to the respected candidate, who need to take part in personality analysis process. The screenshot of AI Analysis is given below.,

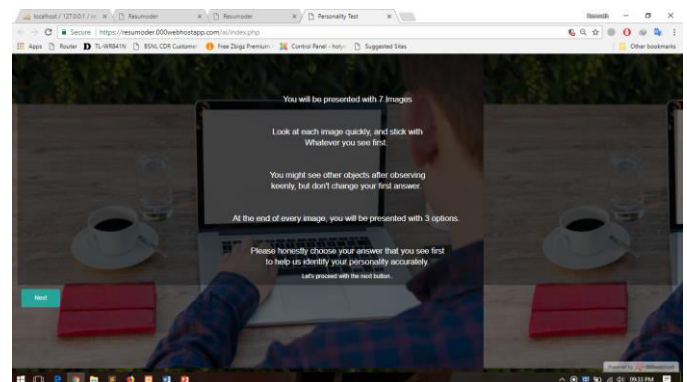

Fig. 9 AI Module Screenshot

### F. References

The reference items of different categories shown in this section include:

- <https://www.w3schools.com/php/default.asp>
- <https://www.tutorialspoint.com/mysql/index.htm>
- <https://www.csstutorial.net/>
- <http://javabeginnerstutorial.com/jsp-tutorial/>
- <https://www.javatpoint.com/what-is-big-data>
- <http://www.resumoder.000webhostapp.com/>

## VIII. CONCLUSIONS

In the future, this application will be updated in the way that, the facial recognition system is included with high definition image scanning devices. And also, the AI algorithm is improved to analyze the user uploaded resume file to predict the user character.

#### IX. ACKNOWLEDGMENT

The author would like to acknowledge the contributions of Mr K. Baskar, Dr. C. Saravanabhavan, Dr. R. Asokan. This work was supported by Big Data Research Laboratory, Kongunadu College of Engineering and Technology.

#### REFERENCES

- [1] "QR Code features". Denso-Wave. Archived from the original on 2013-01-29. Retrieved 3 October 2011.
- [2] "QR Code Essentials". Denso ADC. 2011. Archived from the original on 12 May 2013. Retrieved 12 March 2013.
- [3] Borko Furht (2011). Handbook of Augmented Reality. Springer. p. 341. ISBN 9781461400646. Archived from the original on 21 December 2016.
- [4] Joe Waters. "How to Use the Top QR Code Generators". Dummies.com. Archived from the original on 11 September 2017. Retrieved 5 June 2017.
- [5] "QR Code—About 2D Code". Denso-Wave. Archived from the original on 5 June 2016. Retrieved 27 May 2016.
- [6] "QR Code Standardization". QR Code.com. Denso-Wave. Archived from the original on 10 May 2016. Retrieved 23 May 2016.
- [7] "ISS QR Code|AIM Store: Historical Archive". Aimglobal.org. Archived from the original on 8 August 2016. Retrieved 26 May 2016.
- [8] William P. Banks & Ilya Farber, "Consciousness", in Weiner (ed.), Handbook of Psychology (2003), Volume 4: Experimental Psychology.
- [9] John Bargh and Tanya L. Chartrand, "The Unbearable Automaticity of Being", American Psychologist 54.7, July 1999. Also see: John A. Bargh, "The Automaticity of Everyday Life", in Robert S. Wyer Jr. (ed.), The Automaticity of Everyday Life, Advances in Social Cognition, Volume X; Mahwah, NJ: Lawrence Erlbaum Associates, 1997; ISBN 9780805816990
- [10] John F. Kihlstrom, "The Automaticity Juggernaut—or, Are We Automaton After All?", in John Baer, James C. Kaufman, & Roy F. Baumeister (eds.), Are We Free? Psychology and Free Will; Oxford University Press, 2008. ISBN 978-0-19-518963-6
- [11] For; Siong Soon, Chun; Brass, Marcel; Heinze, Hans-Jochen; Haynes, John-Dylan (2008). "Unconscious determinants of free decisions in the human brain" (PDF). Nature Neuroscience. 11 (5): 543–545. doi:10.1038/nn.2112. PMID 18408715. Archived from the original (PDF) on 22 July 2014.
- [12] Baumeister, Roy F. (2008). "Free Will in Scientific Psychology" (PDF). Perspectives on Psychological Science. 3 (1): 14–19. doi:10.1111/j.1745-6916.2008.00057.x.
- [13] Forgas, Williams, & Laham, "Social Motivation: Introduction and Overview", in Forgas, Williams, & Laham, Social Motivation (2005).
- [14] Weiner, Human Motivation (2013), Chapter 2, "The Psychoanalytic Theory of Motivation" (pp. 9–84).
- [15] Bill P. Godsil, Matthew R. Tinsley, & Michael S. Fanselow, "Motivation", in Weiner (ed.), Handbook of Psychology (2003), Volume 4: Experimental Psychology.