

# SMART SURVEILLANCE SYSTEM USING RASPBERRY PI

1.K.Elamathi

2.B.Gowsika

3.A.Gracy Selusthin

FINAL YEAR – ECE

PSNA COLLEGE OF ENGINEERING AND TECHNOLOGY,DINDIGUL

[1.elamathi2296@gmail.com](mailto:1.elamathi2296@gmail.com) [2.gracyprincy@gmail.com](mailto:2.gracyprincy@gmail.com)

[3.gowsiprincy96@gmail.com](mailto:3.gowsiprincy96@gmail.com)

## ***ABSTRACT:***

Reconnaissance is turning into a need in any open or private zone to adapt up to expanding number of dangers beginning from theft, burglary to psychological oppressor exercises. The customary techniques for observing are regularly restricted in the utilization of CCTV cameras or wireless sensor networks (WSN). These two strategies fill the need in various ways. CCTV cameras help in visual checking of target zones through WSN. This system has joined focal points of the two advancements to develop a keen observation framework. Also it proposed a brought together PC based on application that recognizes the development of people in target region and keep the visual proof of the development with the assistance of the camera. This is an occasion based framework, along these lines, substitutes the requirement for nonstop observing of the territory. The picture is caught by means of the pi camera and it is send to the raspberry pi for handling for face and human identification with the assistance of OpenCV and PIR sensor. At that point, the face recognized is contrasted and the database, if the human distinguished is known (guest) or not (intruder) and in light of the yield, an alarm is created and a message is sent to the owner's mobile. Subsequently, one can give an ease security framework.

**KEYWORDS:** Raspberry pi, web camera(pi camera), PIR sensor,OpenCV,Alarm.

## **INTRODUCTION:**

These days, individuals need one sole thing that is to influence them to feel sheltered and secure. The most usually utilized security framework is the CCTV (closed circuit Television). The cost of usage of CCTV shifts relying on the size and utilization of the framework. It is normally introduced in healing centers, shopping centers, parking areas and so on... However, with the assistance of CCTV one can screen the territory day in and day out, or the recording if put away in an area can be retrieved when required. In spite of the fact that, it can be utilized to stop wrong doing and enables the specialists to distinguish and comprehend a wrongdoing, it doesn't detect neither perceive the individual who is included.

We have actualized a framework which gives both face location and face acknowledgment with the assistance of Raspberry pi which is a minicomputer and a Pi camera(day night vision) which is made particularly for the raspberry pi .

In this manner, when managing the ongoing picture preparing,

Open source PC vision (openCV) programming, an intense library of picture preparing instruments, is a decent decision. With the assistance of a captured observation framework, we have accomplished a framework that can record the occasion, distinguish and perceive the individual. A GSM module is utilized to communicate something specific expressing whether the individual is a stranger or a guest. If the captured image is a visitor, there will be no change in the output. If the image is intended as a stranger, the image of the stranger along with an audio is created.

#### BLOCK DIAGRAM:

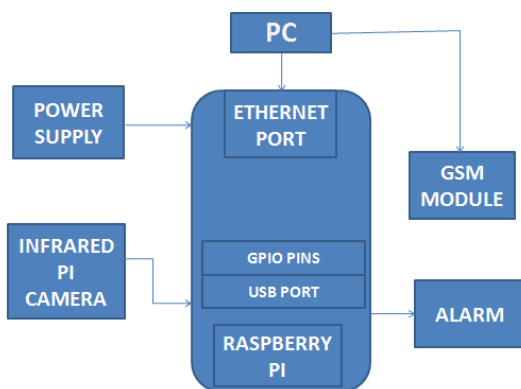

#### COMPONENTS:

1. Raspberry pi
2. pi camera
3. Power supply
4. GSM module

#### 5. Alarm

#### *RASPBERRY PI:*



The raspberry pi 2 is a Mastercard measure PC which is a 900MHz quad-center ARM Cortex-A7 CPU. It has a 1GB RAM and an extra memory is given by utilizing a smaller scale SD card. It has 4 USB ports, 40 GPIO pins. A Full HDMI port is utilized to associate with a show and an Ethernet port is utilized to interface the raspberry pi with the PC. A consolidated 3.5mm sound jack and composite video jack is accessible. There are two kinds of interfaces accessible on the raspberry pi, Camera interface (CSI) for the pi camera and a show interface (DSI).

#### Pi camera:

Raspberry Pi's Camera Serial Interface (CSI) transport connector by means of an adaptable strip link. Christo Ananth et al. proposed a framework in which the cross-jewel look calculation utilizes two precious

# SMART SURVEILLANCE SYSTEM USING RASPBERRY PI

1.K.Elamathi

2.B.Gowsika

3.A.Gracy Selusthin

FINAL YEAR – ECE

PSNA COLLEGE OF ENGINEERING AND TECHNOLOGY,DINDIGUL

[1.elamathi2296@gmail.com](mailto:1.elamathi2296@gmail.com) [2.gracyprincy@gmail.com](mailto:2.gracyprincy@gmail.com)

[3.gowsiprincy96@gmail.com](mailto:3.gowsiprincy96@gmail.com)

stone pursuit designs (a substantial and little) and a midway stop system. It discovers little movement vectors with less pursuit focuses than the DS calculation while keeping up comparable or stunningly better hunt quality. The effective Three Step Search (E3SS) calculation requires less calculation and performs better as far as PSNR. Changed questioned piece base vector seek calculation (MOBS) completely uses the relationships existing in movement vectors to diminish the calculations.

Raspberry pi camera is specially designed for raspberry pi which is equipped for performing face discovery and face acknowledgment of the person. This is being executed in the typical family unit to give security. Barely any adjustments from the existing framework is finished by supplanting the RPI with Raspberry pi 2 with has 900MHz and with 1GB RAM. what's more, it is associated with the pi by means of a 15 stick strip cable. The picture is caught and with the assistance of haar like component course classifier the face is detected. It is a 8mp camera with full HD recording ability.

## **GSM MODULE:**

GSM module is used to send the information to the owner after recognized the face. The sim must be inserted for sending the message.

## **Open CV :**

OpenCV is composed in C++ and its essential interface is in C++, however regardless it holds a lesser complete however broad more established C interface. The API for these interfaces can be found in the online documentation. We have utilized the openCV for the face identification and acknowledgment.

## **WORKING PRINCIPLE:**

The picture is caught by the picamera which has 5MP pixel determination with 30 FPS, this picture is then sent to the face recognition module, which checks the edge got for any appearances that can be found with the assistance of the Haar like highlights, if the face is distinguished then it is trimmed out. Once the face is contrasted and the very much prepared database, it is checked if the face is perceived.

- If the picture matches with the database, at that point the individual is a guest and a message is sent to the client by means of a GSM module showing that somebody who is known has gotten back home.

- However, if the face doesn't coordinate with the database, at that point the individual is distinguished as an outsider, and SMS is sent cautioning the client, and a sound yield is created to caution and alert

the gatecrasher. Alone with the image of the person in the new website page.

Instrumentation Engineering (IJAREEIE), Vol. 3, Issue 3, March 2014, pp 7569-757

#### FLOW CHART:

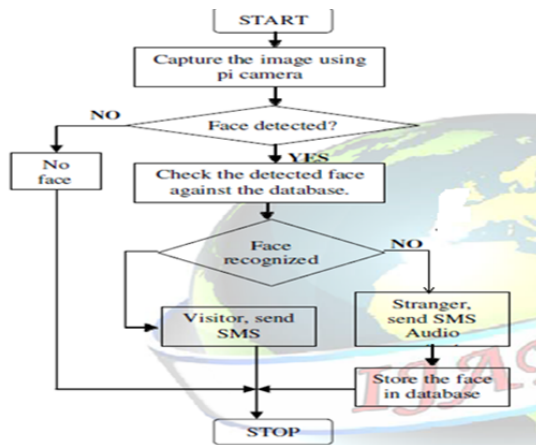

[1] Ms. Naga Jyoti and Mr. K. Vijaya Vardhan, "Design And Implementation Of Real Time Security Surveillance System Using IoT", Communication and Electronics Systems (ICCES), International Conference: IEEE, 2016.

[4] M. Surya Deekshith Gupta, Vamsikrishna Patchava, and Virginia Menezes: "Surveillance and Monitoring System Using Raspberry Pi and SimpleCV": Green Computing and Internet of Things (ICGCIoT), IEEE, 2016

#### CONCLUSION:

Once the stranger's face is detected, an alarming raise of crime is happened along with the perfect image of the stranger is sent to the owner. The image can be viewed by the given web link.

#### APPLICATION:

This project is suitable for highly secured places like banks, houses etc.

#### REFERENCES:

Faizan Ahmad<sup>1</sup>, Aaima Najam<sup>2</sup> and Zeeshan Ahmed<sup>3</sup>, "Image-based Face Detection and Recognition: based Face Detection and Recognition: based Face Detection and Recognition: "State of the Art" "State of the Art", IJCSI International Journal of Computer Science Issues, Vol. 9, Issue 6, No 1, November, 2012, ISSN (Online): 1694-0814

Christo Ananth, A.Sujitha Nandhini, A.Subha Shree, S.V.Ramyaa, J.Princess, "Fobe Algorithm for Video Processing", International Journal of Advanced Research in Electrical, Electronics and

# SMART SURVEILLANCE SYSTEM USING RASPBERRY PI

1.K.Elamathi      2.B.Gowsika      3.A.Gracy Selusthin

FINAL YEAR – ECE

PSNA COLLEGE OF ENGINEERING AND TECHNOLOGY,DINDIGUL

[1.elamathi2296@gmail.com](mailto:1.elamathi2296@gmail.com) [2.gracyprincy@gmail.com](mailto:2.gracyprincy@gmail.com)

[3.gowsiprincy96@gmail.com](mailto:3.gowsiprincy96@gmail.com)



# SMART SURVEILLANCE SYSTEM USING RASPBERRY PI

1.K.Elamathi      2.B.Gowsika      3.A.Gracy Selusthin

FINAL YEAR – ECE

PSNA COLLEGE OF ENGINEERING AND TECHNOLOGY,DINDIGUL

[1.elamathi2296@gmail.com](mailto:1.elamathi2296@gmail.com) [2.gracyprincy@gmail.com](mailto:2.gracyprincy@gmail.com)

[3.gowsiprincy96@gmail.com](mailto:3.gowsiprincy96@gmail.com)