

SMART HELMET USED TO SAVE THE PEOPLE FROM AN ACCIDENT

Yuvalakshmi.K¹, Syed ishaq.I², Mohanraj.S¹

^{1,2}UG scholar, Dept. of ECE, M.Kumarasamy College of Engineering, Karur

¹Assistant professor, Dept. of ECE, M.Kumarasamy College of Engineering, Karur

Abstract— In our today's situation wearing the helmet is the most important thing. Because wearing helmet while driving a bike will avoid from accidents. But most of us are not wearing helmets today because many of us are forgotten to wear that and we do not like that to wear. So people are affecting while the accidents and cause an injury. Now our prototype is about after wearing that helmet only we can start the bike. After wearing that sensor placed helmet in the head only we can start the bike. Because it is almost like a key to start a cycle. We are going to place a touch sensor in that helmet and it will give touch the head and give a key for a bike and it gets to start. So everyone will wear that helmet, due to this many accidents will be avoided. The idea of our project is to first check if the rider has actually worn the helmet, in other words the availability of the rider's head inside the helmet.

Keywords— *Keywords—Index terms; Helmet with bluetooth; Ignition control; RF Transmitter; RF Receiver*

INTRODUCTION

Around 18% of the casualties from street related passing's are walkers in India where when contrasted with 17% of mischance's from traveler autos and taxis and 29% from riders of mechanized a few wheelers. The head protector depicted here once introduced with any bicycle compels the rider to wear it while riding so law or no law the biker should wear the cap guaranteeing his/her own particular wellbeing. Providing safety to a person while riding the bike is of prime concern. One of the ways to do this is by making it mandatory to wear helmet while riding a bike. This is difficult to implement as every time the concerned people can't keep an eye on everybody. The system makes it mandatory for the rider to wear helmet before starting the vehicle and also he shouldn't have consumed alcohol. If the rider fails to do so then the vehicle cannot be started.

'Inadvertent Deaths and Suicides in India' is a yearly production of the National Crime Records Bureau of the Ministry of Home Affairs, Government of India. This report contains far reaching measurements on a scope of viewpoints as to passing's because of mischance's and suicides. The National Summary of Injury Mortality Data gives classifications of the aggregate quantities of passing's also, the death rates per 100,000 populaces for major and other chose outer reasons for death from harm, by race, sexual orientation, and age groupings.

OBJECTIVE OF THE PROJECT

In every methodology the developer needs to send the information in a quick and safe way. By using Zigbee the information gets easily affected to the noise present outside while sending the information.

While using the Wi-Fi, it doesn't have range task and operational restrictions. Control utilization is high when contrasted with different guidelines also, making the battery life low and warmth the framework which we utilize. While using Ad-hoc networks, it has minimal security against the most unwanted incoming signals. Attackers will have generally little difficulty to access the Ad-hoc networks.

To overcome these disadvantages, we are using Bluetooth technology, basically soon; you will see a lot of innovation will be remote because of Bluetooth. As it is now, in any case, no doubt it will be more predominant. It permits you to stay string free and no compelling reason to stress over finding right place for interfacing that additional long line.

Broadly utilized

Bluetooth is currently truly famous and continues getting more prevalent as time cruises by. Organizations are taking the advantage by utilizing this in their new and future items to make life much less demanding for everybody.

Highlight simplicity

You don't have to know much about innovation keeping in mind the end goal to run Bluetooth. Anybody that doesn't have any learning about the new innovation can at present can utilize the Bluetooth include because of its straightforwardness and the convenience.

LITERATURE REVIEW

Prevailing System

The existing project basically has a wireless telecommunication, and is connected to a smart phone. This prototype uses sensors to detect a crash or accidents and the communication hardware is used to automatically dial a predefined emergency contact. The other existing system is to control the speed in which the biker is going in. The helmet is fixed with all the components and sensors that read the speed of the bike and accordingly instruct the rider to reduce or increase the speed based on the obstacles ahead the bike. Along

with the speed limit sensors the helmet also checks if the rider is drunk and driving. If the rider is drunk then the ignition of the bike is avoided and hence not letting the rider to ride the bike.

By Using Zigbee System

It is a high level communication protocol used in small areas like home automation, medical device data collection and it is designed mainly for small scale projects. This device is less expensive than Bluetooth and Wi-Fi. The transmission distance range limits from 10 to 100 meters which is not applicable for transmitting information's from electricity board to the consumer's home. Zigbee is used in low data rate applications and it consumes more battery power. This system will not withstand for long period of time and may cause in wrong generation of output. This methodology is not applicable for our project

Using Ad-Hoc Networks

The primary issues in Ad-hoc systems are their strategy for directing and normal for remote system. In Ad-hoc arrange, a hub can discuss just with a hub in its territory. It is a major disadvantage in this methodology. These nodes can communicate with other nodes but the routing algorithm is necessary for every nodes. The infrastructure of this network is complex and too expensive. Using Wi-Fi method Wireless Fidelity depends on IEEE 802.11 norms. The Module without wire has partial action and it is related for residence networking. For instance, a home switch with Wi-Fi in a room has a less range contrasted with a long separation transmission. This cannot be used in long range applications. The information can be easily transmitted and received but it is not applicable for long range if distances. So this methodology is not applicable for our project where electricity board and consumer's home vary for a greater distances.

PROPOSED SYSTEM

In our today situation wearing the helmet is the most important thing. Because wearing helmet while driving a bike will avoid from accidents. But most of them are not wearing helmets today because many of them are forgotten to wear that and they do not like that to wear. So people are affecting while the accidents and cause an injury.

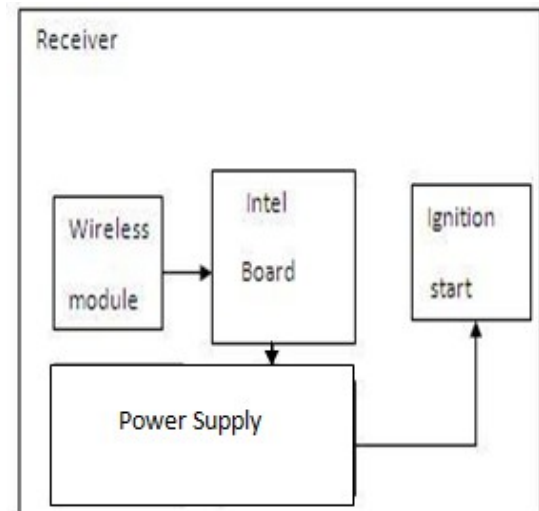
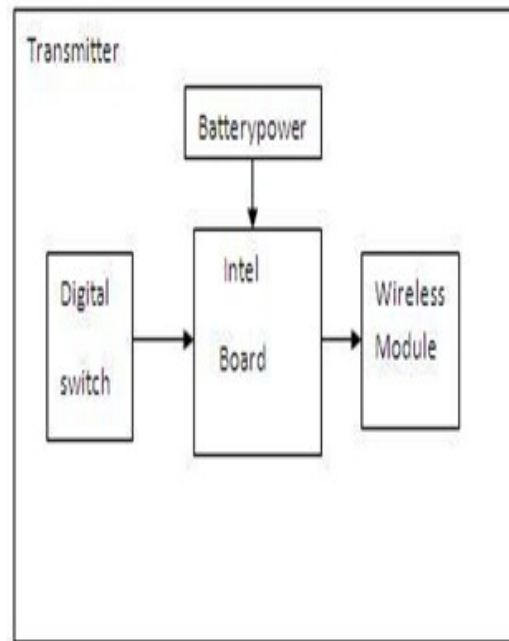

Now our prototype is about after wearing that helmet only we can start the bike. By this we can avoid so many accidents in this world, most of the accidents are occurring due to without wearing helmet, our government is introducing lot of rules to wear helmet but our people is not responding for that, so this is a better way to follow the rules and to avoid accident. After wearing that sensor placed helmet in the head only we can start the bike. Because, it is almost like a key to start a bike. We are going to place a touch sensor in that helmet and it will give touch the head and give a key for a bike and it gets to start. So everyone will wear that helmet, due to this many accidents will be avoided. People don't get injured and we can save them by this method.

The idea behind this project is by placing the digital switch sensor and Intel board in helmet. After wearing the helmet the

HARDWARE DESCRIPTION

INTEL GALILEO GEN-2 KIT

The Intel Galileo Gen 2 supports Arduino readymade hardware expansion cards. It is open source software from where the coding is very easy. The coding in Intel Galileo Gen 2 and Arduino are same. Important drawback in Intel Galileo Gen 2 was so cost, Which is higher.

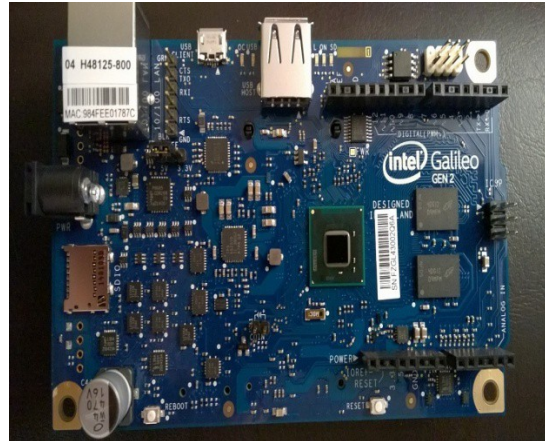

DIGITAL BUTTON SENSOR

A push-catch or simply button is a basic switch component for controlling some part of a machine or a procedure. Catches are commonly made out of hard material, as a rule [plastic](#) or else [metal](#). The shell is generally even otherwise fashioned en route for hold the person finger otherwise hand, in order to be effortlessly depressed or else pushed. The "push-catch" has been used in mini-computers, phones, kitchen apparatuses, and different other mechanical and electronic gadgets, home and business. In mechanical and business applications, push catches can be associated together by a mechanical linkage so that the demonstration of pushing one catch causes the other catch to be discharged. Along these lines, a stop catch can "drive" a begin catch to be discharged. This technique for linkage is utilized as a part of basic manual operations in which the machine or process have no electrical circuits for control.



Administrator won't push the wrong catch in mistake. Usually utilized hues are red for halting the machine or process and green for beginning the machine or process. Push knob

output of digital switch is transferred from helmet to the Intel board in bike via wireless module. After getting the input Intel board ON the relay switch which is connected between battery power and ignition start. By this we cannot start the bike and so we can avoid from death. The correspondence amongst protective cap and brilliant dashboard is built up utilizing Bluetooth, in this way giving secure and certain connection between the two. System of farthest point switch with appropriate mechanical gathering introduced inside the protective cap is utilized to distinguish the head protector wearing marvel. We have to fit the rear side of the helmet with a battery operated transmitter system, a small antenna and a switch in the helmets inside panel. The FM receiver with an antenna is installed near the ignition coil on the bike, with a connection to the bike's battery and relay system. The Arduino is an extremely easy to use gadget which can be effortlessly interfaced with any sensors or modules and is extremely minimal in size. Now all are clear that the Arduino will send an affirmation to the bike for an ignition request.

IMPLEMENTATION OF SMART HELMET

In this equipment setup incorporates the transmitter and recipient segments, the transmitter segments have liquor detecting component, microcontroller unit, encoder and transmitter leaf switches are here. The beneficiary segment have decoder and collector, microcontroller unit, start control, electrical gadget, sound and visual sign, control supply and so on.



In future we can utilize this in vogue head protector in No stopping zones and furthermore in No section zones. It will diminish the work of Traffic polices. In future we can use this in vogue head defender in No ceasing zones and moreover in No segment zones. It will decrease the work of Traffic polices. By this we can dodge part of mischance's. In up and coming days we will design the savvy head protector in a conservative size. So we can convey the shrewd cap wherever we require.

switches are mechanical switches characterized by the strategy used to enact the switch.

WIRELESS MODULE

Remote correspondence is the exchange of data or power between at least two focuses that are not associated by an electrical conveyor.



When you utilize PCs, diversion frameworks or phones, the different pieces and parts of the frameworks make up a group of electronic gadgets. There are heaps of various ways that electronic gadgets can interface with each other. For model:

- ✓ element cables
- ✓ Electrical ropes
- ✓ Ethernet cables
- ✓ [Wireless-Fidelity](#)
- ✓ Infrared signal

The craft of associating things is turning out to be increasingly mind boggling each day. In this editorial, we will take a gander at a technique for interfacing gadgets, called Bluetooth that can modernize the procedure. A Bluetooth association is remote and programmed; also, it has various fascinating and adventuring components Which is wireless.



FUTURE SCOPE

In future we have an idea to design our project in compact size and also we will design our project to indicate No entry and No parking area. No parking area is mainly allocated for repairing and development of road sides. At that situation our bike won't run it will stop immediately.



CONCLUSION

This project represents an example of systematic approach to avoid the people from accidents. Thus only by wearing the helmet we can start the bike. By this we can avoid many accidents in this world, most of the accidents are occurring because of not wearing helmet, our government is introducing lot of rules to wear helmet but our people is not responding for that, so this is a better way to follow the rules to avoid accident and save the people from the heavy head injury.

IX. REFERENCES

- [1] Bishop R, "The road ahead for intelligent vehicle system: what's in store for riders?" s 8th Annual Minnesota Motorcycle safety conference, 2012.
- [2] Sayeed and A. Perrig, "Secure Wireless Communications: Secret Keys through Multipath", Proc. IEEEInt'l Conf. Acoustics, Speech Signal Processing, pp. 3013-3016, Apr.2008
- [3] William R. Reagen, "Auto theft detection system- US4177466 (US Patent) Computer," May 2011.
- [4] V.Kavitha, V.Palanisamy, "New Burst Assembly and Scheduling T technique for Optical Burst Switching Networks", Journal of Computer Science, Vol. 9, Issue 8, pp.1030-1040, 2013.
- [5] V.Kavitha, V.Palanisamy, "Simultaneous Multi-path Transmission for Burst Loss Recovery in Optical Burst Switching Networks", European Journal of Scientific Research, Vol. 87, Issue 3, pp.412-416, 2012.
- [6] S.Palanivel Rajan, K.Sheik Davood, "Performance Evaluation on Automatic Follicles Detection in the Ovary", International Journal of Applied Engineering Research, Vol.10, Issue 55, pp.1-5, 2015.
- [7] S.Mohanapriya, M Vadivel, "Automatic retrieval of MRI brain image using multiqueries system", 2013 International Conference on Information Communication and Embedded Systems (ICICES), INSPEC Accession Number: 13485254, Electronic ISBN: 978-1-4673-5788-3, DOI: [10.1109/ICICES.2013.6508214](https://doi.org/10.1109/ICICES.2013.6508214), pp. 1099-1103, 2013.
- [8] S.Palanivel Rajan, "Review and Investigations on Future Research Directions of Mobile Based Tele care System for Cardiac Surveillance", Journal of Applied Research and Technology, Vol.13, Issue 4, pp.454-460, 2015.
- [9] S.Palanivel Rajan, M.Paranthaman, Dr.C.Vivek, "Design and Enhancement of Wideband Reconfigurability using Two E-Shaped Patch Antenna", Asian Journal of Research in Social Sciences and Humanities, ISSN : 2249-7315, Vol.6, Issue 9, pp. 317-327, 2016.
- [10] C.Vivek, S.Palanivel Rajan, "Z-TCAM : An Efficient Memory Architecture Based TCAM", Asian Journal of Information Technology, Vol.15, Issue 3, pp.448-454, 2016.

