

Department of Electrical and Electronics Engineering

Academic Year 2024-2025

Year/Semester: II/III	Department : EEE Subject Code/Title : EE3303 / ELECTRICAL MACHINES -I	UNIT-1-5 (Questions Bank) Faculty Name : Dr.P.Pounraj
-------------------------------------	---	--

UNIT-I ELECTROMECHANICAL ENERGY CONVERSION

PART – A

1.Mention the types of electrical machines.

There are three basic rotating machines types, namely

- The dc machines
- The poly phase synchronous machine (ac), and
- Poly and single phase induction machine (ac) and a stationary machine, namely transformer

2.State Ohm's law for magnetic circuit.

It states that the magneto motive force across the magnetic element is equal to the product of the magnetic flux through the magnetic element and the reluctance of the magnetic material. It is given by

$$\text{MMF} = \text{Flux} \times \text{Reluctance}$$

3.Define leakage flux

The flux setup in the air paths around the magnetic material is known as leakage flux.

4.Define magnetic reluctance

The opposition offered by the magnetic circuit for the magnetic flux path is known as magnetic reluctance. It is analogous to electric resistance.

5.Draw the typical normal magnetization curve of ferromagnetic material.

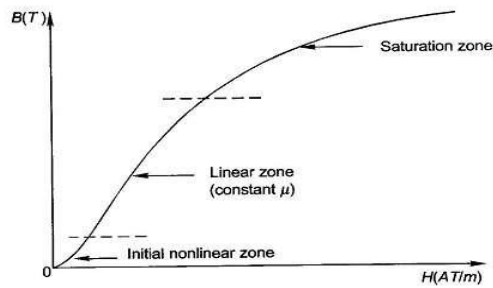

Fig. 2.3 Typical normal magnetization curve of ferromagnetic material

6. What is fringing?

In the air gap the magnetic flux fringes out into neighbouring air paths due to the reluctance of air gap which causes a non uniform flux density in the air gap of a machine. This effect is called fringing effect.

7. State stacking factor.

The stacking factor is defined as the ratio of the net cross sectional area of a magnetic core to the gross cross sectional area of the magnetic core. Due to lamination net cross sectional area will be always less than gross cross sectional area. Therefore the value of stacking factor is always less than unity.

8. Mention some magnetic materials

Alnicos, chromium steels, copper–nickel alloy, nickel, cobalt, tungsten and aluminium.

9. What is magnetostriction?

When ferromagnetic materials are subjected to magnetizing mmf, these may undergo small changes in dimension; this phenomenon is known as magnetostriction.

10. Define statically induced emf.

The coil remains stationary with respect to flux, but the flux through it changes with time. The emf induced is known as statically induced emf.

11. Define dynamically induced emf.

Flux density distribution remains constant and stationary but the coil move relative to it. The emf induced is known as dynamically induced emf.

12. State Fleming's right hand rule.

Extend the thumb, fore and middle finger of the right hand so that they are mutually perpendicular to each other. If the thumb represents the direction of movement of conductor and the fore finger the direction of magnetic flux, then the middle finger represents the direction of emf.

13. State Fleming's Left hand rule.

Extend the thumb, fore and middle finger of the right hand so that they are mutually perpendicular to each other. If the forefinger represents the direction of flux and the middle finger the direction of current, then the middle finger represents the direction of movement of conductor.

14. What are the losses called as core loss?

Hysteresis loss and eddy current loss.

15. Define coercivity.

It is the measure of mmf which, when applied to the magnetic circuit would reduce its flux density to zero, i.e., it demagnetizes the magnetic circuit.

16. What is an electromechanical system?

The system in which the electromechanical energy conversion takes place via the medium of a magnetic or electric field is called electromechanical system.

17. Describe multiply excited magnetic field system.

The specially designed transducers have the special requirement of producing an electrical signal proportional to forces or velocities of producing force proportional to electrical signal. Such transducers require two or more excitations called as multiply excited magnetic field system.

18. Define co energy.

Co energy is an energy used for a linear system computation keeping current as constant. It will not be applied to the non-linear systems.

19. How energy is stored?

Energy can be stored or retrieved from the magnetic system by means of an exciting coil connected to an electric source.

20. Define field energy.

The energy drawn by virtue of change in the distance moved by the rotor in electrical machines in field configuration is known as field energy.

21. Draw the graphical relation between field energy and co-energy

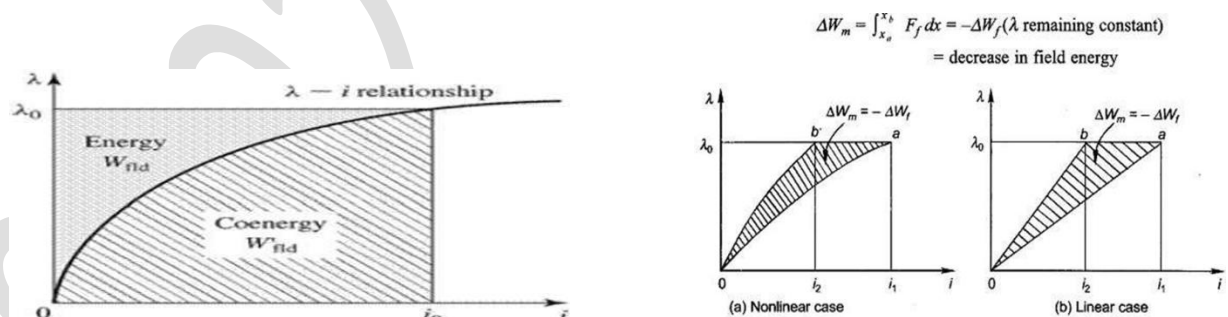

22. Define the term pole pitch

The distance between the centres of two adjacent poles is called pole pitch, one pole pitch is equal to 180 electrical degrees. It is also defined as the number of slots per pole.

23. Define pitch factor

It is defined as the ratio of resultant emf when coil is short pitched to the resultant emf when coil is full pitched. It is always less than one. Pitch factor is always termed as coil span (Kc) factor

$$k_c = \cos \alpha/2 \text{ where } \alpha = \text{angle of short pitch}$$

24. Define the term breadth factor

The breadth factor is also called distribution factor or winding factor. The factor by which there is a reduction in the emf due to distribution of coil is called distribution factor denoted as k_d .

25. Write down the advantages of short pitched coil.

The length required for the end connection of coils is less i.e., inactive length of winding is less. So less copper is required. Hence economical.

Short pitching eliminated high frequency harmonics which distort the sinusoidal nature of emf. Hence waveform of an induced emf is more sinusoidal due to short pitching.

As high frequency harmonics get eliminated, eddy current and hysteresis losses which depend on frequency also get minimized. This increases the efficiency.

26. What is distributed winding?

If 'x' conductors per phase are distributed amongst the 3 slots per phase available under pole, the winding is called distributed winding.

27. Explain the following terms with respect to rotating electrical machines.

- a) Pole pitch
- b) Chording angle.

Pole pitch: The distance between the centres of two adjacent poles is called pole pitch. One pole pitch is equal to 180 electrical degrees. It is also defined as the number of slots per pole.

Chording angle: It is defined as that angle by which the coil pitch departs from 180 electrical degrees.

PART-B & C

1. **Derive the expression for field energy produced in a doubly excited magnetic field system?**
2. **The magnetic flux density on the surface of an iron face is 1.6 T which is a typical saturation level value for ferromagnetic material. Find the force density on the iron face.**
3. **What are the special applications where the electric field is used as a coupling medium for electromechanical energy conversion? Also explain why electric field coupling is preferred in such applications?**
4. **Find an expression for the force per unit area between the plates of a parallel plate condenser in terms of the electric field intensity. Use both the energy and co energy methods. Find the value of the force per unit area when $E = 3 \times 10^6$ V/m, the breakdown strength of air.**

5. Explain with neat diagram and sufficient expressions, the multiply excited magnetic field systems.
6. Explain i - characteristics of a magnetic system. Also derive the expression for co energy density. Assume i - relationship of the magnetic circuit is linear.
7. Explain the concept of singly – excited machines and derive the expression for the electromagnetic torque.
8. (a) Explain about the magnetization curve of Ferro –magnetic material.
(b) Derive the relation between mutual inductance and self inductances of two magnetically coupled coils.
9. (a) Explain AC operation of magnetic circuits.
(b) Explain in detail about hysteresis and eddy current losses.

UNIT II DC GENERATORS

1.State the basic parts of a DC machine.

Stationary Parts: Frame, Main pole, field coils, inter poles, inter pole winding Rotating Parts: Armature core, Armature winding, Commutator, Shaft.

2.Name the various parts of a DC machine that control the magnetic circuit.

Poles, Air-gap, Armature core, Yoke.

3.What is prime mover?

The basic source of mechanical power which drives the armature of the generator is called prime mover.

4.How is voltage generated in rotating machines?

In rotating machines voltage is generated in windings or group of coils by rotating them through a magnetic field or by mechanically rotating a magnetic field past the winding or by designing the magnetic circuit so that the reluctance varies with rotation of the rotor.

5.Write down the emf equation for d.c generator.

$E = (\Phi NZ / 60)(P/A) V$ Where, P= number of poles Z= Total number of conductors A= number of parallel paths Φ = flux per pole N= speed in rpm.

6. Why is Commutator employed in d.c machines? Or what is the function of a commutator in a DC generator?

- Conduct electricity between armature and fixed brushes
- Converts alternating emf into unidirectional emf and vice versa

7. Define critical field resistance in dc shunt generator.

Critical field resistance is defined as the resistance of the field circuit which will cause the shunt generator just to build up its emf at a specified field.

8. Why is the emf not zero when the field current is reduced to zero in a dc generator?

Even after the field current/magnetizing force is reduced to zero the machine is left out with some flux as residue. Emf due to this residual flux is available when field current is zero.

9. Define the term „critical speed“ in dc shunt generator.

Critical speed is defined as the speed at which the generator is to be driven to cause self-excited generator to build up its emf for the given field circuit resistance.

10. On what occasions dc generators may not have residual flux?

- The generator may be put for its first operation after its construction.
- In previous operation the generator would have been fully demagnetized.

11. What are the conditions to be fulfilled for a dc shunt generator to build up emf?

- The generator should have residual flux
- The field winding should be connected in such a manner that the flux set up by the field winding should be in the same direction as that of residual flux
- The field circuit resistance should be less than critical field resistance
- Load circuit resistance should be above its critical load resistance

12. What are the types of DC starters?

1. Two point starters
2. Three point starters
3. Four point starters

13. What are the major categories of losses in a DC machine?

Magnetic losses, Electrical losses, Mechanical losses

14. Why are carbon brushes preferred for dc machines?

The high contact resistance carbon brushes help the current in the coil undergoing commutation to attain its full value in the reverse direction at the end of commutation. The carbon brushes also lubricate and give less wear and tear on commutator surface.

15. Name any two applications of DC series generator.

Booster, electric welding, Constant current source, Constant illumination

16. What is the basic principle of a dc generator?

Basic principle of a dc generator is Faraday's law of electromagnetic induction. i.e. whenever a conductor is moved in a magnetic field, dynamically induced emf is produced in that conductor.

17. What is the purpose of yoke in a dc machine? Or The outer frame of a DC machine serves double purpose. What are they?

- It acts as a protecting cover for the whole machine and provides mechanical support for the machine.
- It carries the magnetic flux produced by the poles. The flux per pole divides at the yoke so that; the yoke carries only half the flux produced by each pole.

18. What are the causes of failure of dc shunt generator to excite?

- The residual magnetism may not be present in the poles.
- The field winding may not be properly connected with armature.
- Under no load condition, the shunt field resistance should be greater than the critical field resistance.
- Under loaded condition, the shunt field resistance should be less than the critical field resistance.

19. List the important parts of a DC starter.

Starting resistance, Handle, over load relay, No voltage relay

20. What are the drawbacks of brake test on DC machines?

- The brake test can be used for small motors only, because in case of large motors, it is difficult to dissipate the large amount of heat generated at the brake.
- This method cannot be used for determining internal losses.
- The output of the motor cannot be measured directly.

21. What is the purpose of yoke in a dc machine?

The purpose of yoke in a dc machine is to

1. Act as a protective cover for the whole dc machine
2. Provide a support for poles
3. Provide a magnetic path for the flow of flux lines.

22. Name the different parts of a dc generator. Answer: The different parts of a dc generator are,

1. Magnetic frame or Yoke,
2. Poles or Field magnets,
3. Armature,
4. Commutator, brushes,
5. Field windings & Armature windings.

23. State the applications of DC generator. The applications of DC generator are,

1. Separately excited DC generator - Used in electroplating and electro refining of metals.
2. Shunt generator - Used in charging batteries and as main generator in ships
3. Series generator - Used to add voltage to transmission line and to compensate for the line drop.
4. Compound generator - Used to supply power to railway circuits and elevator motors.

24. Write the emf equation of a DC generator.

The emf equation of a DC generator is,

$$E_g = \frac{P\phi NZ}{60A}$$

where, E_g – emf induced in generator (V) P – Number of poles

Φ – Flux per pole (Wb)

N – Speed of machine (rpm) Z – Number of conductors

A – Number of parallel paths.

25. Give the different types of dc machine.

The types of dc machine are

- a) Self Excited Generator
 - 1. Shunt Generator
 - 2. Series Generator
 - 3. Compound Generator: (i) Long Shunt (ii) Short Shunt
- b) Separately Excited Generator

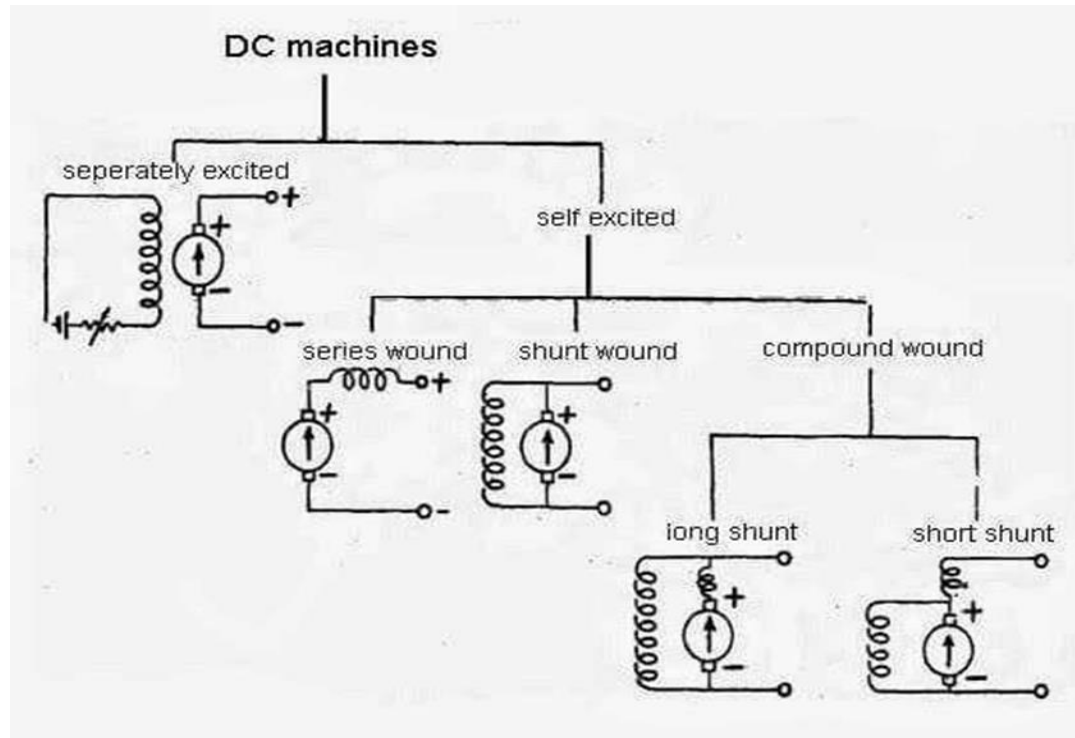

PART-B & C

1. Describe different kinds of commutation in detail.
2. Explain various methods of excitation for DC machines?.
3. Explain briefly about the classification on DC generators with neat diagram?
4. Explain briefly about the no load and the open circuit characteristics of a separately excited generator
5. Explain about the Load characteristic of shunt generator?
6. Derive the expression for EMF induced in the generator.
7. A 6 pole lap wound rotated at 350 r.p.m. is required to generate 300V. the useful flux per pole is 0.05 Wb. If the armature has 120 slots . calculate the number of conductors per slot.

8. A 25 KVA, 250 V dc shunt generator has armature and field resistance of 0.06 and 125 respectively. Calculate the total power developed by the armature when it delivers full load output.
9. A 250 KVA, 400 V, 6 pole dc shunt generator has 720 lap wound conductors. It is given a brush lead of angular degrees from the geometric neutral. Determine the cross and demagnetizing turns per pole. Neglect the shunt field current.
10. Explain about the Parallel operation of shunt generators.
11. (a) Describe with sketches the construction of a DC machine.
(b) Derive the EMF equation of DC generator.
12. Draw and explain the no-load and load characteristics of DC shunt, series and compound generators.
13. Explain the effect of armature reaction in a DC shunt generator. How is its demagnetizing and cross-magnetizing ampere turns calculated?
14. Explain the process of commutation in a DC machine.
15. With a aid of a circuit diagram, describe the procedure for paralleling two DC shunt generators and for transferring the load from one machine to the other.
16. A 4-pole, 50 kW, 250 V, wave wound shunt generator has 400 armature conductors. Brushes are given a lead of 4 commutator segments. Calculate the demagnetization ampere- turns per pole if shunt field resistance is 50 ohm. Also calculate extra shunt field turns per pole to neutralize the demagnetization.
17. A 4-pole, lap connected DC machine has 540 armature conductors. If the flux per pole is .03 Wb and runs at 1500 RPM, determine the emf generated. If this machine is driven as a shunt generator with same field flux and speed, calculate the line current if the terminal voltage is 400V. Given the $R_{SH}=450\text{ohm}$ and $R_A=2\text{ohm}$.
18. Two separately excited DC generators are connected in parallel and supply a load of 200A. The machines have armature circuit resistances of 0.05 ohm and 0.1 ohm and induced emfs of 425V and 440V respectively. Determine the terminal voltage, current and power output of each machine. The effect of armature reaction is to be neglected.
19. Write in detail about armature reaction in dc machines

UNIT 3 DC MOTOR

1.To what polarity the inter poles excited in dc motors?

For motor operation the polarity of the inter poles must be that of the previous main pole along the direction of rotation.

2.Name any four applications of DC series motor.

Electric traction

Mixies

Hoists

Drilling machines

3.Why DC motors are not operated to develop maximum power in practice?

The current obtained will be much higher than the rated current. The efficiency of operation will be below 50%.

4.Name the starters used for series motors.

Face plate type.

Drum type controller.

5.Name Different types of starters

1.Three point starter

2.Four point starter.

6.Name the Protective devices in a starter.

1, No volt release

2. Overload Release.

7.What are the modification in ward Leonard linger system?

1.Smaller motor and generator set

2.Addition of flywheel whose function is to reduce fluctuations in the power demand from the supply circuit.

8.What type of DC motors are suitable for various torque operations?

- 1.DC series motor
- 2.DC cumulatively compound motor

9.Define speed regulation.

$\% \text{ Speed regulation} = \frac{\text{NL speed} - \text{FL speed}}{\text{FL speed}} \times 100$

10. What are the performance curves?

Output Vs torque
Output Vs current Output Vs speed Output Vs efficiency

11.To what polarity are the inter poles excited in dc generators?

The polarity of the inter poles must be that of the next main pole along the direction of rotation in the case of generator.

12.Why are carbon brushes preferred for dc machines?

The high contact resistance carbon brushes help the current in the coil undergoing commutation to attain its full value in the reverse direction at the end of commutation. The carbon brushes also lubricate and give less wear and tear on commutator surface.

13.What are the various types of commutation?

Linear commutation
Sinusoidal commutation

14.Name the two methods of improving commutation.

(i)Emf commutation. (ii)Resistance commutation

15.What is reactance emf in dc machine?

The self-induced emf in the coil undergoing commutation which opposes the reversal of current is known as reactance emf

16. What is prime mover?

The basic source of mechanical power, which drives the armature of the generator, is called prime mover.

17. Give the materials used in machine manufacturing

Three materials are used in machine manufacturing.

- (i) steel—to conduct magnetic flux
- (ii) Copper—to conduct electric current
- (iii) Insulation

18. How will you change the direction of rotation of a d.c motor?

Either the direction of the main field or the direction of current through the armature conductors is to be reversed.

19. What is back emf in d.c motors?

As the motor armature rotates, the system of conductor come across alternate North and South Pole magnetic fields causing an emf induced in the conductors. The direction of the emf induced in the conductors. The direction of the emf induced is in the direction opposite to the current. As this emf always opposes the flow of current in motor operation it is called back emf.

20. Under what condition the mechanical power developed in a dc motor will be maximum?

Condition for mechanical power developed to be maximum is $E_b = U_a / 2$ or $I_a = U_a / 2R_a$

21. What is the function of no-voltage release coil provided in a dc motor starter?

As long as the supply voltage is on healthy condition the current through the NVR coil produce enough magnetic force of attraction and retain the starter handle in the ON position against spring force. When the supply voltage fails or becomes lower than a prescribed value, the electromagnet may not have enough force and the handle will come back to OFF position due to spring force automatically. Thus no-voltage or under voltage protections given to the motor.

22. Name the two types of automatic starters used for dc motors.

Back emf type starter

Time delay type starter.

23.Enumerate the factors on which the speed of a dc motor depends.

The speed of dc motor depends on three factors.

Flux in the air gap

Resistance of the armature circuit

Voltage applied to the armature

24.List the different methods of speed control employed for dc series motor.

Field diverter method

Regrouping of field coils

Tapped field control

Armature resistance control

Armature voltage control for single motor

Series parallel control for multiple identical motors.

25.Name the different methods of electrical braking of dc motors.

(i)Dynamic braking

(ii)Regenerating braking

(ii)Counter current braking or plugging

26.Name any four applications of DC series motor.

Electric traction

Mixies Hoists

Drilling machines

27.Why DC motors are not operated to develop maximum power in practice?

The current obtained will be much higher than the rated current. The efficiency of operation will be below 50%.

28. Name the starters used for series motors.

Face plate type.

Drum type controller

PART B & C

1. (a) Explain the principle of operation of a DC motor.

(b) A shunt machine, connected to 200V mains has an armature resistance of 0.15 and field resistance is 100 . Find the ratio of its speed as a generator to its speed as a motor, line current in each case being 75 A.

2. (a) Draw and explain the mechanical characteristics of DC series and shunt motor.

(b) A 230V, DC shunt motor, takes an armature current at 3.33A at rated voltage and at a no load speed of 1000RPM. The resistances of the armature circuit and field circuit are 0.3 and 160 respectively. The line current at full load and rated voltage is 40A. Calculate, at full load, the speed and the developed torque in case the armature reaction weakens the no load flux by 4%.

3. (a) Describe the working of 3 point starter for DC shunt motor with neat diagram.

(b) Explain Ward-Leonard method of speed control in DC motors.

4. (a) Derive an expression for the torque developed in a DC machine.

(b) A 220V, Dc shunt motor with an armature resistance of 0.4 ohm and a field resistance of 110ohm drives a load, the torque of which remains constant. The motor draws from the supply, a line current of 32A when the speed is 450 RPM. If the speed is to be raised to 700RPM, what change must be effected in the value of the shunt field circuit resistance? Assume that the magnetization characteristic of the motor is a straight line.

5. Explain the different methods used for the speed control of D.C. shunt motor.

6. (a) Explain in detail about circuit model of D.C. machine.

(b) A 440 V D.C shunt motor takes 4A at no load . its armature and field resistances are 0.4 ohms and 220 ohms respectively .estimate the kW output and efficiency when the motor takes 60A on full load.

7. (a) Derive an expression for the torque developed in the armature of a D.C. motor.
 (b) Determine developed torque and shaft torque of 220V, 4 pole series motor with 800 conductors wave-connected supplying a load of 8.2 kW by taking 45A from the mains. The flux per pole is 25m/Wb and its armature circuit resistance is 0.6 ohm.
8. With the help of neat circuit diagram, explain Hopkinson's test and derive the relations for efficiency (both for generator and motor) also state the merits and demerits of this method.
9. (a) Explain in detail about different methods of excitation. (b) Derive the expression for efficiency of D.C. machines.
10. With a neat diagram, Explain the constructional details of a DC motor
11. Explain the characteristics of a series motors.
12. With the help of neat circuit diagram, explain swinburne's test and derive the relations for efficiency (both for generator and motor) also state the merits and demerits of this method.

UNIT 4 TRANSFORMER

1. Mention the difference between core and shell type transformers.

In core type, the windings surround the core considerably and in shell type the core surround the winding.

2. What is the purpose of laminating the core in a transformers ? (April -98)

To reduce eddy current loss.

3. Give the emf equation of a transformer and define each term (April -99)

Emf induced in primary coil $E_1 = 4.44 f \Phi m N_1$ volt

Emf induced in secondary coil $E_2 = 4.44 f \Phi m N_2$ volt where f is the frequency of AC input

Φm is the maximum value of flux in the core

N_1, N_2 are the number of primary and secondary turns.

4.Does the transformer draw any current when secondary is open ? Why ?

Yes, it (primary) will draw the current from the main supply in order to magnetise

the core and to supply iron and copper losses on no load . There will not be any current in the secondary since secondary is open.

5.Define voltage regulation of a transformer (April –98)

When a transformer is loaded with a constant primary voltage , the secondary voltage decreases for lagging power factor load, and increases for leading pf load because of its internal resistance and leakage reactance . The change in secondary terminal voltage from no load to full load expressed as a percentage of no load or full load voltage is termed as regulation .

$$\% \text{ regulation down} = (V_2 - V_2') \times 100 / V_2$$

$$\% \text{ regulation up} = (V_2 - V_2') \times 100 / V_2'$$

6.Full load copper loss in a transformer is 1600 watts. What will be the loss at half load ?

If x is the ratio of actual load to full load then copper loss = x^2 (full load copper loss). Here $W_c = (0.5)^2 \times 1600 = 400$ watts.

7.Define all day efficiency of a transformer

It is the computed on the basis of energy consumed during a certain period , usually a day of 24 hrs.

$$\eta \text{ (all day)} = \text{output in kWh} / \text{input in kWh for 24 hrs.}$$

8.Why transformers are rated in kVA ? (May 03)

Copper loss of a transformer depends on current and iron loss on voltage . Hence total losses depend on Volt- Ampere and not on the power factor. That is why the rating of transformers are in kVA and not in kW.

9.What are the typical uses of auto transformer ?

(i)To give small boost to a distribution cable to correct for the voltage drop.

(ii)As induction motor starters.

(iii)As furnace transformers

(iv)As interconnecting transformers

(v)In control equipment for single phase and 3 phase electric locomotives.

10. What are the applications of step-up and step-down transformers?

Step-up transformers are used in generating stations. Normally the generated voltage will be either 11 kV or 22 kV. This voltage is stepped up to 110 kV or 220 kV or 400 kV and transmitted through transmission lines. (In short it may be called as sending end). Step-down transformers are used in receiving stations. The voltage are again stepped down to 11 kV or 22 kV and transmitted through feeders. (In short it may be called as receiving end). Further these 11 kV or 22kV are stepped down to 3 phase 400 V by means of a distribution transformer and made available at consumer premises. The transformers used at generating stations and receiving stations are called power transformers.

11. How transformers are classified according to their construction? Or Mention the difference between “CORE” and “SHELL” type transformers. Or What are the two types of cores used ? Compare them.

Transformers are classified according to their construction as,

(i) Core type (ii) Shell type (iii) Spirakore type.

Spirakore type is a latest transformer and is used in big transformers. In “core” type, the windings (primary and secondary) surround the core and in “shell” type, the core surround the windings.

12. Explain on the material used for core construction. (Oct 02)

The core is constructed of transformer sheet steel laminations assembled to provide a continuous magnetic path with a minimum of air gap included. The steel used is of high silicon content sometimes heat-treated to produce a high permeability and a low hysteresis

loss at the usual operating flux densities. The eddy current loss is minimized by laminating the core, the laminations being insulated from each other by light coat of core-plate varnish or by an oxide layer on the surface. The thickness of laminations varies from 0.35 mm for a frequency of 59 Hz and 0.5 mm for a frequency of 25 Hz.

13. When will a Buchholz relay operate in a transformer?

Buchholz relay is a protective device in a transformer. If the temperature of the coil exceeds its limit, Buchholz relay operates and gives an alarm.

14. How does change in frequency affect the operation of a given transformer?

With a change in frequency, iron loss, copper loss, regulation, efficiency and heating varies and thereby the Operation of the transformer is affected.

15. What is the angle by which no-load current will lag the ideal applied voltage?

In an ideal transformer, there are no copper loss and no core loss, (i.e. loss free core). The no load current is only magnetizing current. Therefore the no-load current lags behind by an angle of 90° . However the windings possess resistance and leakage reactance and therefore the no-load current lags the applied voltage slightly less than 90° .

16. List the advantages of stepped core arrangement in a transformer.

- (i) To reduce the space effectively.
- (ii) To obtain reduced length of mean turn of the windings.
- (iii) To reduce I^2R loss.

17. Why are breathers used in transformers?

Breathers are used to entrap the atmospheric moisture and thereby not allowing it to pass on to the transformer oil. Also to permit the oil inside the tank to expand and contract as its temperature increases and decreases. Also to avoid slogging of oil i.e. decomposition of oil.

Addition of 8 parts of water in 1000000 reduces the insulations quantity of oil. Normally silica gel is filled in the breather having pink colour. This colour will be changed to white due to continuous use, which is an indication of bad silica gel, it is normally heated and reused.

18. What is the function of transformer oil in a transformer?

Nowadays instead of natural mineral oil, synthetic oils known as ASKRELS (trade name) are used. They are non inflammable; under an electric arc do not decompose to produce inflammable gases. PYROCOLOR oil possesses high dielectric strength. Hence it can be said that transformer oil provides, (i) good insulation and (ii) cooling.

19. A 1100/400 V, 50 Hz single phase transformer has 100 turns on the secondary winding. Calculate the number of turns on its primary.

We know that $V_1 / V_2 = k = N_2 / N_1$ Substituting in above equation $400/1100 = 100/N_1$

$$N_1 = 100/400 \times 1100$$
$$= 275 \text{ turns.}$$

20. What are the functions of no-load current in a transformer?

No-load current produces flux and supplies iron loss and copper loss on no-load.

21. How will you transfer the quantities from one circuit to another circuit in a transformer?

1. Secondary to primary 2. Primary to secondary

Symbol Value Symbol Value

$V_2 = V_1/k$, $V_L = kV_1$, $I_2 = kI_1$, $I_L = I_1/k$

$R_2' = R_2/k^2$, $R_L' = k^2R_1$, $X_2' = X_2/k^2$, $X_L' = k^2X_1$, $Z_L' = Z_L/k^2$

22. Can the voltage regulation of a transformer go to negative? If so under what condition?

Yes. If the load has leading power factor.

23. Distinguish between power transformer and distribution transformer.

Power transformers have very high power ratings in the order of MVA. They are used in generating and receiving stations. Sophisticated controls are required. Voltage ranges will be very high. Distribution transformers are used in consumer side. Voltage levels will be medium. Power ranging will be small in order of kVA. Complicated controls are not needed.

24. What is the purpose of providing 'taps' in transformer and where these are provided?

In order to attain the required voltage, 'taps' are provided. Normally it will be provided at low voltage sides

25. Give the method of reducing iron loss in a Transformer (Oct -98)

The iron losses are minimized by using high-grade core material like silicon steel having very low hysteresis loop and by manufacturing the core in the form of laminations.

26. State the condition for maximum efficiency (Oct - 97)

Copper losses = Iron losses

PART-B & C

1. Draw and explain the no load phasor diagram of a single phase transformer.

2.(a) Derive the emf equation of single phase transformer.

3. A 100 kVA, 6.6kV/415V, single phase transformer has an effective impedance of $(3+8j)$ referred to HV side. Estimate the full load voltage regulation at 0.8 pf lagging and 0.8 leading pf.
4. The emf per turn of a single phase, 6.6kV/440V, 50 Hz transformer is approximately 12V. Calculate the number of turns in the HV and LV windings and the net cross sectional area of the core for a maximum flux density of 1.5T.
5. Obtain the equivalent circuit of a 200/400V, 50Hz, single phase transformer from the following test data:
OC test: 200V, 0.7A, 70W on LV side
SC test: 15V, 10A, 85W on HV side.
6. Draw the circuit diagrams for conducting OC and SC tests on a single phase transformer. Also explain how the efficiency and voltage regulation can be estimated by these tests.
7. (a) Derive the condition for maximum efficiency in a transformer.
(b) A 11000/230 V, 150 KVA, 1-phase, 50 Hz transformer has core loss of 1.4kW and F.L cu loss of 1.6 Kw. Determine (i) The kVA load for maximum efficiency and the value of maximum efficiency at unity p.f. (ii) The efficiency at half F.L 0.8 pf leading.
8. Explain in detail about parallel operation of single phase transformers.
9. Data of a 500KVA, 3300/400 V, 50 Hz, single phase transformer is given below.
S.C test: 1250 W, 100 V – secondary short circuited with full load current in it
O.C test: 1000 W – with normal primary voltage. Calculate the full load regulation and efficiency at a power factor of 0.8(lag).
10. (a) Derive the equivalent circuit of a single phase two winding transformer.
(b) The maximum efficiency of a single phase 250kVA, 2000/250 V transformer occurs at 80% of full load and is equal to 97.5% at 0.8 pf. Determine the efficiency and regulation on full load at 0.8pf lagging the impedance of the transformer is 9 percent.
11. Explain in detail about tap changing of transformers.
12. The emf per turn of a single phase, 6.6kV/440V, 50 Hz transformer is approximately 12V. Calculate the number of turns in the HV and LV windings and the net cross sectional area of the core for a maximum flux density of 1.5T.

13. Obtain the equivalent circuit of a 200/400V, 50Hz, single phase transformer from the following test data:

- a. OC test: 200V, 0.7A, 70W on LV side
- b. SC test: 15V, 10A, 85W on HV side.

14. The maximum efficiency of a single phase 250kVA, 2000/250 V transformer occurs at 80% of full load and is equal to 97.5% at 0.8 pf. determine the efficiency and regulation on full load at 0.8pf lagging if the impedance of the transformer is 9%.

15. A 11000/230 V, 150 KVA, 1-phase, 50 Hz transformer has core loss of 1.4kW and F.L cu loss of 1.6 Kw. determine the kVA load for maximum efficiency and the value of maximum efficiency at unity p.f and the efficiency at half F.L 0.8 pf leading.

UNIT 5

THREE PHASE TRANSFORMER AND AUTO TRANSFORMER

1. What is step down transformer?

The transformer used to step down the voltage from primary to secondary is called as step down transformer. (Ex: 220/110V).

2. Draw the no-load phasor diagram of a single phase transformer.

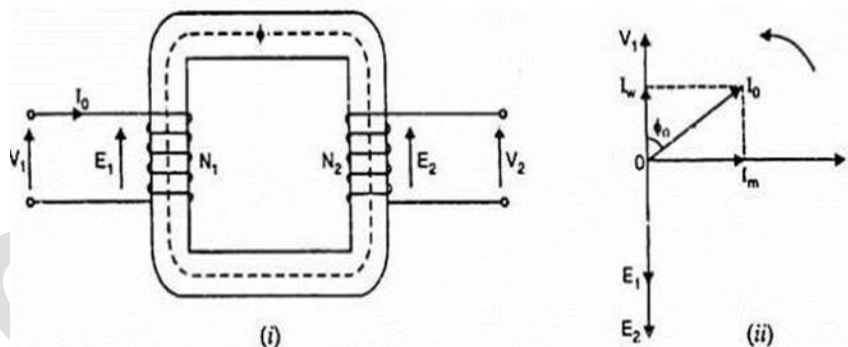

3. Why is an auto-transformer not used as a distribution transformer?

The autotransformer cannot provide isolation between HV and LV side. Due to open circuit in the common portion, the voltage on the load side may shoot up to dangerously high voltage causing damage to equipment. This unexpected rise in the voltage on LV side is potentially dangerous. Hence the autotransformer cannot be used as distribution transformer.

4. Give the basic principle behind the working of transformer.

The transformers works in the principle of mutual induction between two coils which are electrically isolated but magnetically coupled.

5.What are the conditions for parallel operation of transformer?

In order that the transformers work satisfactorily in parallel, the following conditions should be satisfied:

- i Transformers should be properly connected with regard to their polarities.
- ii The voltage ratings and voltage ratios of the transformers should be the same. ñ The per unit or percentage impedances of the transformers should be equal.
- ñi The reactance/resistance ratios of the transformers should be the same.

6.What are the no load losses in a two winding transformer? And state the reasons for such losses.

The no-load losses in transformer are,

- i Hysteresis Loss: To establish the magnetic circuit in the transformer core.
- ñ Eddy current loss: Due to circulation of current induced in the core due to induction.

7.Why is transformer rated in kVA?

The copper loss of a transformer depends on current and iron loss on voltage. Hence, total transformer loss depends on volt-ampere (VA) and not on phase angle between voltage and current i.e., it is independent of load power factor. That's why rating of transformers are in kVA and not in kW.

8.Compare two winding transformer and auto-transformer.

Particulars	Two Winding Transformer	Auto Transformer
No. Of windings	Two windings	One winding
Output voltage	Fixed unless tap changer is provided	Variable voltage can be obtained
Weight of Copper	required More for two windings	Less because of single winding
Size	Larger for same rating	Small in size for same rating
Efficiency	Comparatively lesser	Comparatively better

9. Classify the transformer according to the construction.

Depending upon the manner in which the primary and secondary are wound on the core, transformers are of two types viz., (i) core-type transformer and (ii) shell-type transformer.

10. What is transformation ratio?

It is the ratio in which the voltage to be transformed (stepped up or down) from primary to secondary of a transformer.

11. Draw the exact equivalent circuit of a transformer.

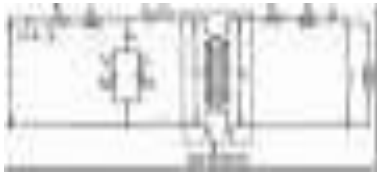

12. What are the advantages of auto-transformer over ordinary transformer?

- i The autotransformer is lesser size than ordinary two winding transformer for the same rating. Hence the cost reduced.
- ñ Autotransformer operates at higher efficiency. ñ Superior voltage regulation.

13. Mention the properties of oil used in transformers.

The following are the desirable properties of transformer oil:

- It should be free from moisture
- It should have high dielectric strength
- It should have thermally stability and higher thermal conductivity
- It should be contaminated by temperature rise.

14. Define voltage regulation of transformer.

The voltage regulation of a transformer is the arithmetic difference (not phasor difference) between the no-load secondary voltage (V_2) and the secondary voltage V_2 on load expressed as percentage of no-load voltage.

15. Write down the volt-ampere transferred inductively and volt-ampere transferred conductively in an auto-transformer.

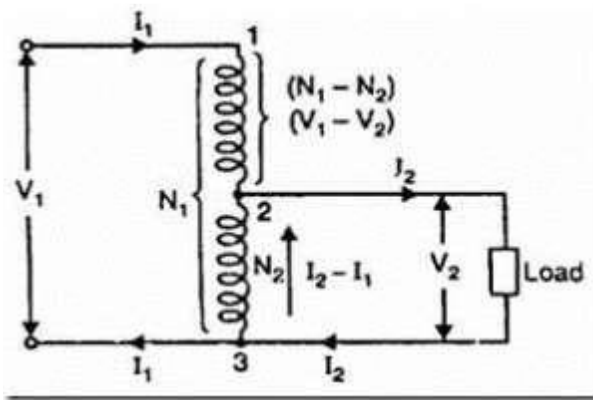

16. What are the properties of an ideal transformer?

An ideal transformer has the following properties:

- i. No winding resistance
- ii. No flux leakage
- iii. No core loss
- iv. Magnetize at zero current

17. Mention the applications of auto-transformer.

The autotransformers are used in the following applications:

- i. To give small boost to a distribution cable to correct the voltage drop.
- ii. As auto transformer starter to give upto 50% to 60% of full voltage to an induction motor during starting.
- iii. As furnace transformers for getting a convenient supply to suit the furnace winding from a 230V supply.
- iv As interconnection transformers in 132kV/330kV system.
- v. In control equipment for single phase and three phase electrical locomotives.

18. Why $V_1:V_2 \neq N_1:N_2$ in a real (practical) transformer?

In practical transformers, the terminal output depends on the resistive drop and magnetic leakages. Hence the ratio of turns do not match equal with the ratio of terminal voltages.

19. Explain the term percentage impedance as applied to transformer.

The percentage impedance is the per-unit impedance expressed as a percentage on a certain MVA and voltage base.

20. What are the various types of three phase transformer connections? The most common types of transformer connections are,

- i. Star-Star (Y-Y)
- ii. Delta-Delta (Δ - Δ)
- iii. Star-Delta (Y- Δ)
- iv. Delta-Star (Δ -Y)
- v. Open Delta (V-V)
- vi. Scott Connection (T-T)

21. What is an ideal transformer?

The transformer has the following properties is said to be an ideal transformer: ñ No winding resistance

ñ No flux leakage ñ No core loss

ñ Magnetize at zero current

In practical, it is difficult to satisfy all the above properties and the concept of ideal transformer is only an imaginative.

22. What are the two components of no-load current in transformer? The no-load current contains two components as follows:

1. Loss component (I_w)
2. Magnetizing component (I_m)

23. What is All day efficiency?

The ratio of output in kWh to the input in kWh of a transformer over a 24-hour period is known as all-day efficiency i.e.,

All day Efficiency = Output kWh for 24Hrs / Input kWh for 24Hrs

24. Define regulation and efficiency of a transformer.

The voltage regulation of a transformer is the arithmetic difference (not phasor difference) between the no-load secondary voltage (V_2) and the secondary voltage V_2 on load expressed as percentage of no-load voltage. The efficiency of a transformer is defined as the ratio of output power (in watts or kW) to input power (watts or kW). $\eta = \text{Output Power} / \text{Input Power}$.

25. Mention the different losses in transformer. The losses that occur in a transformer are:

- (a) core losses—eddy current and hysteresis losses
- (b) copper losses—in the resistance of the windings.

PART-B & C

1.(a) Explain the working of auto transformer and prove that when transformation ratio approaches unity, the amount copper used approaches smaller value.

2.(a) Explain the principle and operation of auto transformer.

(b) A 120kVA, 6000/400V, Y/Y, 3-phase, 50Hz transformer has a iron loss of 1800W. The maximum efficiency occurs at $\frac{3}{4}$ full loads. Find the efficiency of the transformer at

- (i) Full load and 0.8 pf**
- (ii) The maximum efficiency at unity pf.**

3. With the help of circuit diagrams, explain any two types of three phase transformer connections.

4. Explain the Construction of three phase transformer.

5. Describe the various three phase transformer connections.

6. What are the applications of Scott connection.

7. What are the applications of auto transformer.

8. Compare auto transformer with two winding transformer.